

## Features

- Made of high quality synthetic quartz crystal
- Available with large size aperture
- Design for reduction of phase retardation dispersion is available

## Applications

- LCD projector
- Various test equipment
- Various laser devices
- Optical unit for manufacturing equipment

## Specifications

Specifications	Type	Monolithic Quarter Wave Plate	Double Layer Quarter Wave Plates	Monolithic Half Wave Plate	Double Layer Half Wave Plates
Phase retardation		90°±5° (at the center of wavelength)		180°±5° (at the center of wavelength)	
Crystal plate azimuth		Y-cut or X-cut		Y-cut or X-cut	
Wavelength		350 to 2100nm		350 to 2100nm	
Optical axis tolerance		±1°		±1°	
Outline dimensions		φ20 to 76.2mm, 5 to 40mm square		φ20 to 76.2mm, 5 to 40mm square	
Thickness (C)		≒ 0.2mm	0.4 to 1.0mm	≒ 0.4mm	0.4 to 1.0mm
Angle of incident		Vertical		Vertical	
Transmittance		More than 98% (AR coating on both surface)		More than 98% (AR coating on both surface)	
Wave front aberration		On discussion		On discussion	

\* Please consult us for specifications other than the above.

\* Air-gap type with the holder is available.

## Dimensions

(Unit: mm)

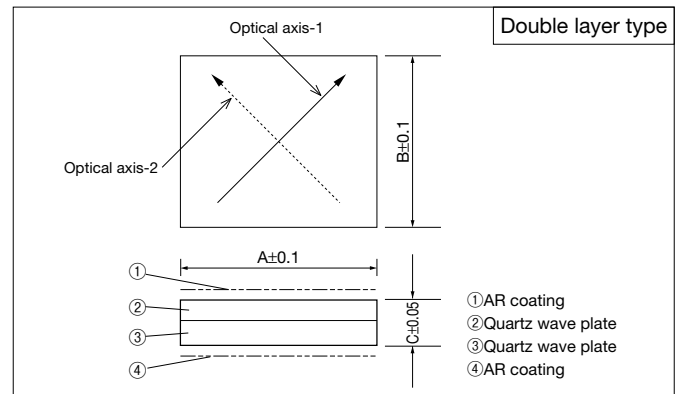
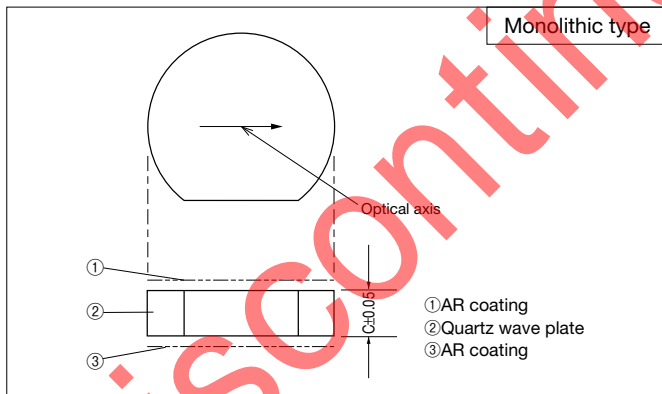

## Anti-reflection Coating Characteristics (Example)

