

水晶振動子 (Crystal Unit)

HC-49/U

マイクロプロセッサ, VTR & Color-TV用水晶振動子 / Resistance Weld Crystal for Microprocessor, VTR, Color-TV

■特長 / Feature

- 高さ13.46mm、体積は従来品 (HC-18/U, HC-43/U) と同等です。
- レジスタンス・ウエルドの完全密封型です。
- 周波数安定度が良く、信頼度が高い。
- 高密度実装対応、量産機種に最適です。
- Height 13.46mm, volume equivalent to the former product (HC-18/U, HC-43/U).
- A resistance weld completely sealed type.
- The frequency stability is good, the reliability is high.
- Copes with high density mounting and is optimum for mass production models.

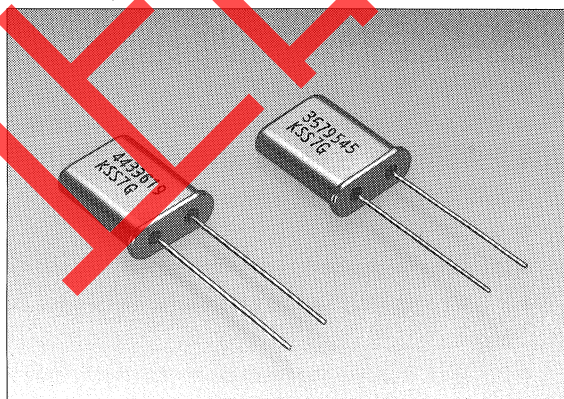

■仕様 / Specification (For Microprocessor)

型名 (Type)	HC-49/U
周波数範囲 (Frequency Range)	3~66.7MHz
標準周波数 (Standard Frequency)	Table 1
オーバートーン次数 (Overtone Order)	3~24MHz: Fundamental 24.1~66.7MHz: 3rd overtone
動作温度範囲 (Operating Temp. Range)	-20~+70°C
周波数偏差 (Frequency Tolerance)	at 25°C: $\pm 50 \times 10^{-6}$ Over The Oper. Temp. Range: $\pm 50 \times 10^{-6}$ (referred to 25°C)
負荷容量 (Load Capacitance)	Table 1
等価直列抵抗 (Equivalent Series Resistance)	3.0MHz~3.4 MHz: 500 Ω MAX. 3.5MHz~4.4 MHz: 100 Ω MAX. 4.5MHz~4.999MHz: 80 Ω MAX. 5.0MHz~5.199MHz: 75 Ω MAX. 5.2MHz~5.999MHz: 70 Ω MAX. 6.0MHz~24.0 MHz: 60 Ω MAX. 24.1MHz~66.7 MHz: 60 Ω MAX.
並列容量 (Shunt Capacitance)	7.0pF MAX.
励振レベル (Drive Level)	1mW MAX.
耐衝撃性 (Shock)	硬質木板上20cm高、自然落下3回 (Three drops onto a hard wood board from the height of 20cm)
耐振性 (Vibration)	周波数10~55Hz 全振幅0.7~0.9mm 直交3方向各2時間 (10to55Hz, Amplitude 0.7~0.9mm, Cycle minute 3 directions, 2hours each)

■仕様 / Specification (For VTR & Color TV)

型名 (Type)	HC-49/U	
周波数 (Nominal Frequency)	3579.545kHz 4433.619kHz	14318.18kHz 17734.476kHz
動作温度範囲 (Operating Temp. Range)	-10~+70°C	
周波数偏差 (Frequency Tolerance)	at 25°C: $\pm 30 \times 10^{-6}$ Over The Oper. Temp. Range: $\pm 30 \times 10^{-6}$ (referred to 25°C)	
負荷容量 (Load Capacitance)	16pF	
等価直列抵抗 (Equivalent Series Resistance)	90 Ω MAX.	50 Ω MAX.
並列容量 (Shunt Capacitance)	7.0pF MAX.	
励振レベル (Drive Level)	1mW MAX.	
耐衝撃性 (Shock)	硬質木板上20cm高、自然落下3回 (Three drops onto a hard wood board from the height of 20cm)	
耐振性 (Vibration)	周波数10~55Hz 全振幅0.7~0.9mm 直交3方向各2時間 (10to55Hz, Amplitude 0.7~0.9mm, Cycle minute 3 directions, 2hours each)	

■外形寸法 / Outline

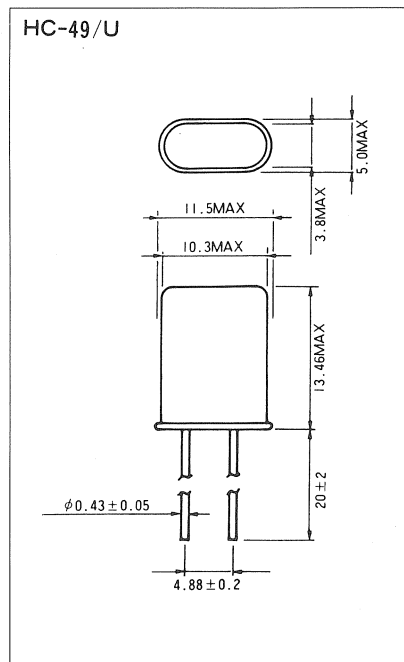

Dimensions (mm)

■Table 1 標準周波数 / Standard Frequency

周波数 (MHz)	負荷容量 (pF)	周波数 (MHz)	負荷容量 (pF)	周波数 (MHz)	負荷容量 (pF)	周波数 (MHz)	負荷容量 (pF)
3.000	16	6.144	16	11.0592	16	19.6608	16
3.579545	16	6.400	16	12.000	16	20.000	16
3.6864	16	7.200	16	14.31818	16	22.1184	16
4.000	16	7.3728	16	14.7456	16	24.000	16
4.194304	13.2	8.000	16	15.000	16	27.000	12
4.433619	16	8.6436	16	16.000	16	28.63636	12
4.500	16	9.216	16	16.384	16	32.000	12
4.9152	16	10.000	16	17.734476	16	33.8688	12
5.000	16	10.738635	16	18.000	16	36.000	12
6.000	16	11.000	16	18.432	16	48.000	12