

Datasheet of SAW Filter

1411 GPS

KYOCERA Part No. : SF14-1575M5UBB1

KYOCERA Corporation
All rights reserved

Rating

| Items | Rating | Unit | Note |
|-------------------------------|------------|-------|----------------------------|
| Operating Temperature Range | -30 to +85 | deg.C | |
| Storage Temperature Range | -40 to +85 | deg.C | |
| Max Input Power | +12 | dBm | 5,000Hours, Ta=50deg.C, CW |
| Input Port Nominal Impedance | 50 | ohm | Unbalance |
| Output Port Nominal Impedance | 100 | ohm | Balance |

Dimensions

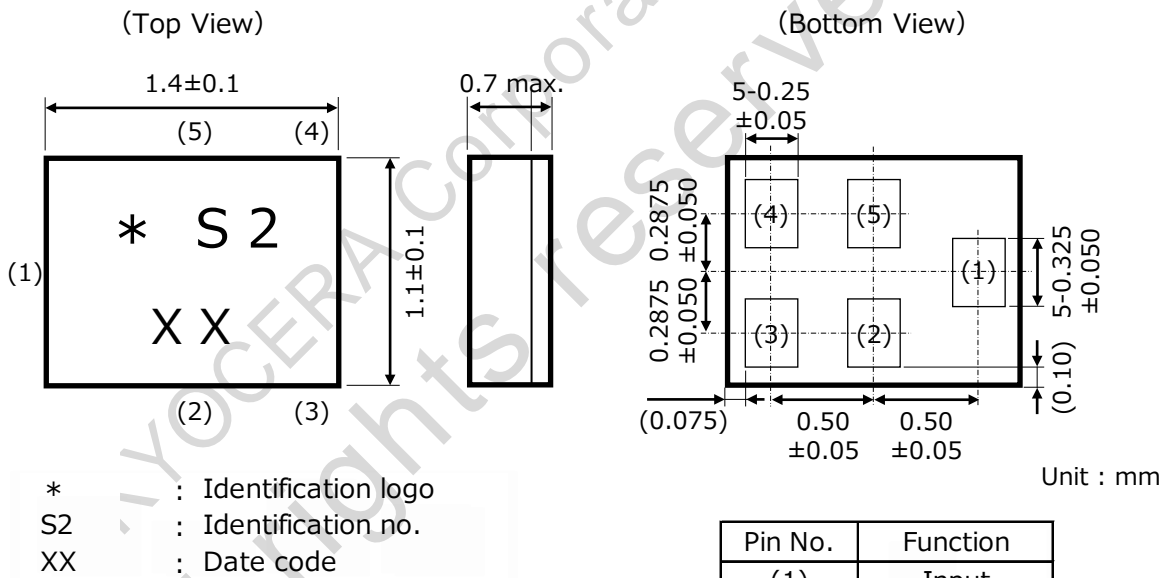

| Pin No. | Function |
|---------|----------|
| (1) | Input |
| (3) | Output |
| (4) | Output |
| Others | GND |

Recommendable Land Pattern

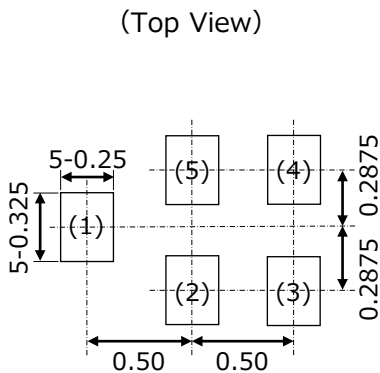

Measurement Circuit

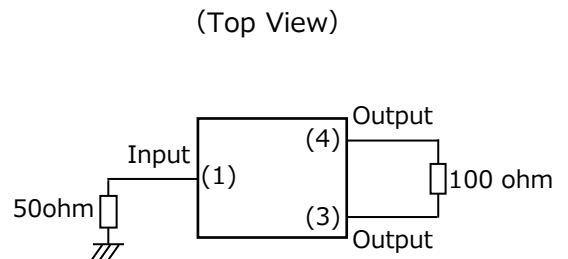

Electrical Characteristics

| | Frequency (MHz) | Characteristics | | | Unit | Note |
|--------------------------------|--------------------|-----------------|------|------|------|------|
| | | min. | typ. | max. | | |
| Nominal Frequency | - | 1575.42 | | | MHz | |
| Insertion Loss | 1574.42 to 1576.42 | - | 1.7 | 2.0 | dB | |
| Amplitude Ripple(peak to peak) | 1574.42 to 1576.42 | - | 0.05 | 1.0 | dB | |
| Input VSWR | 1574.42 to 1576.42 | - | 1.3 | 1.8 | - | |
| Output VSWR | 1574.42 to 1576.42 | - | 1.1 | 1.8 | - | |
| Absolute Attenuation | 10 to 250 | 50 | 76 | - | dB | |
| | 250 to 810 | 50 | 63 | - | dB | |
| | 810 to 960 | 50 | 58 | - | dB | |
| | 960 to 1429 | 32 | 36 | - | dB | |
| | 1429 to 1453 | 35 | 40 | - | dB | |
| | 1453 to 1525 | 30 | 38 | - | dB | |
| | 1525 to 1560 | 3 | 6 | - | dB | |
| | 1625 to 1920 | 23 | 28 | - | dB | |
| | 1920 to 1980 | 50 | 54 | - | dB | |
| 1980 to 5000 | 35 | 42 | - | dB | | |
| Amplitude Imbalance | 1574.42 to 1576.42 | -1.8 | -0.6 | +1.8 | dB | |
| Phase Imbalance | 1574.42 to 1576.42 | -11.0 | -4.5 | +11 | deg. | |

Electrical Characteristics

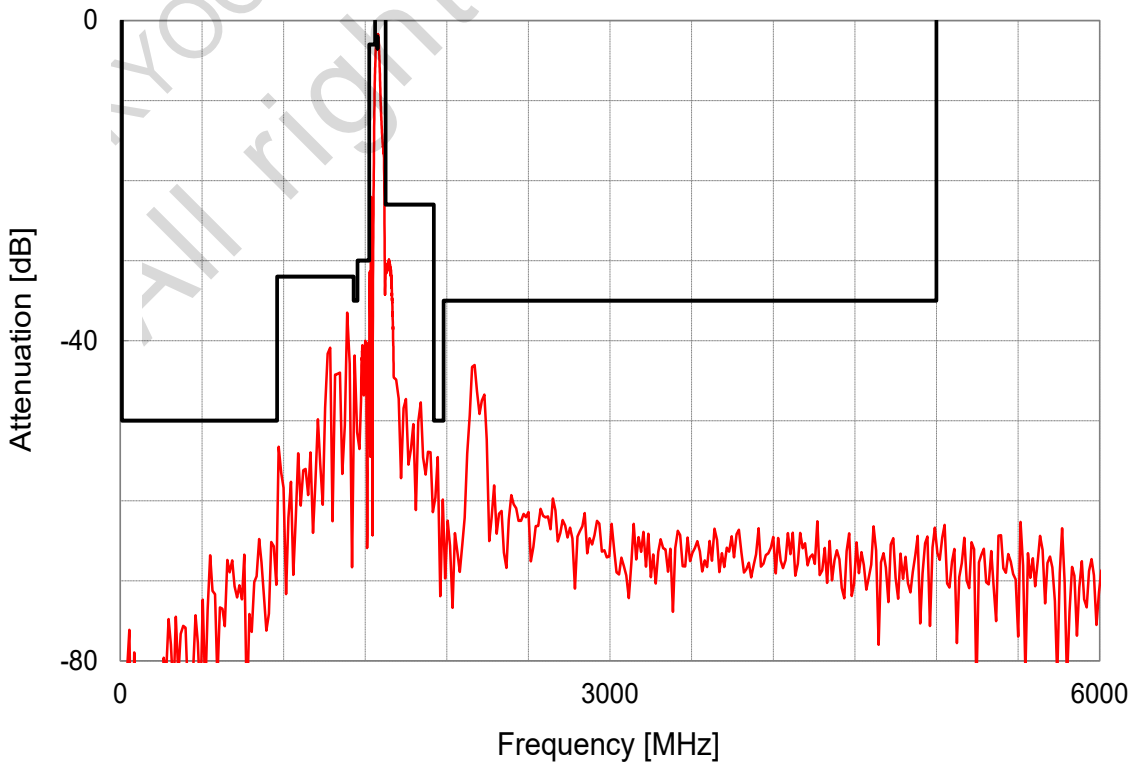
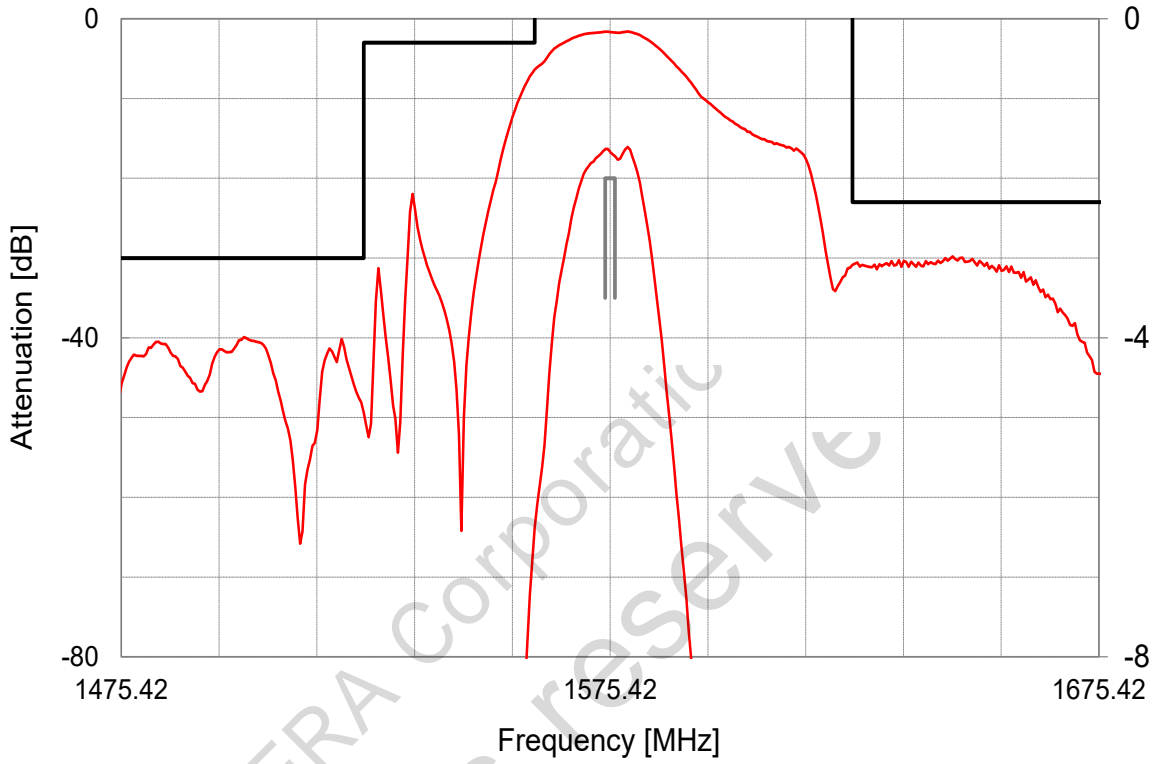

Electrical Characteristics

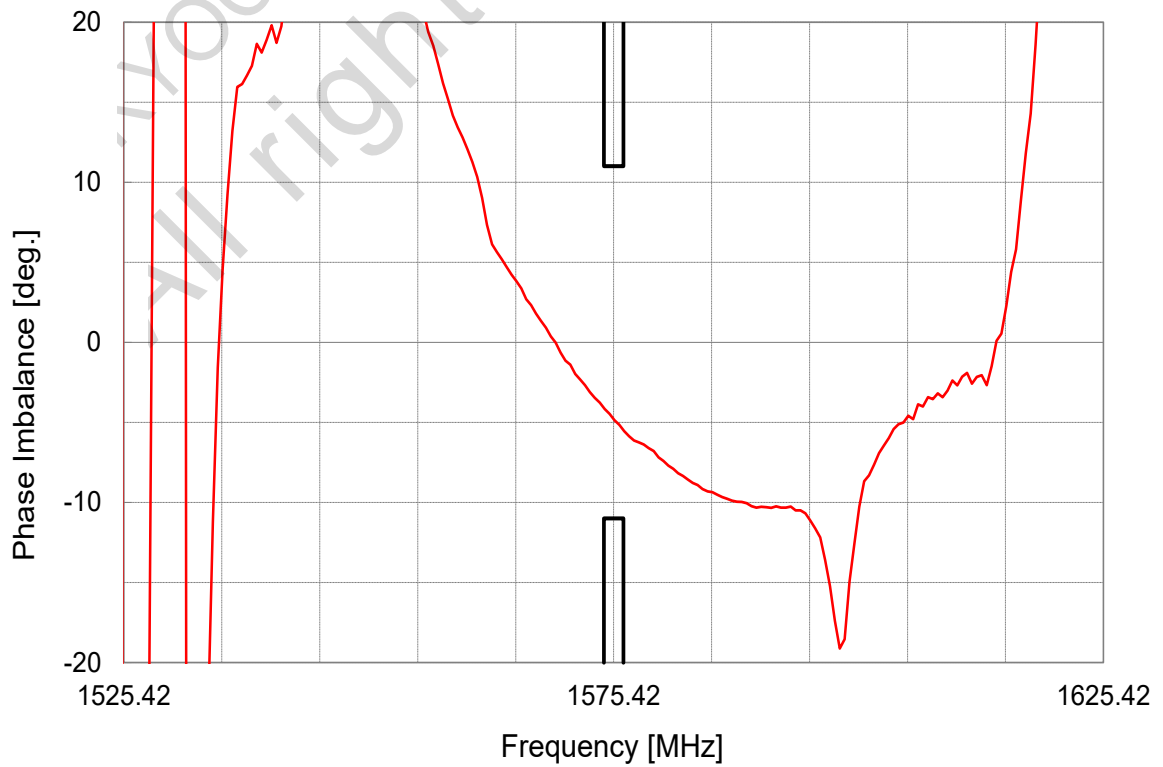
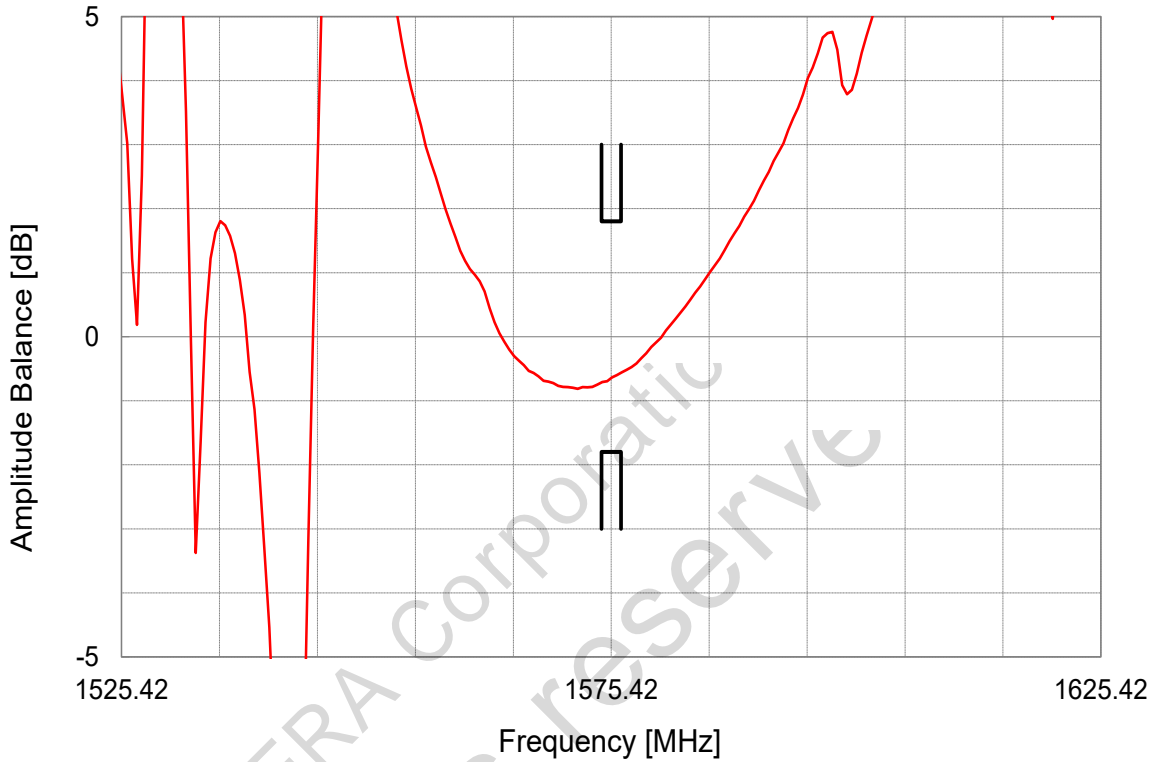

Electrical Characteristics

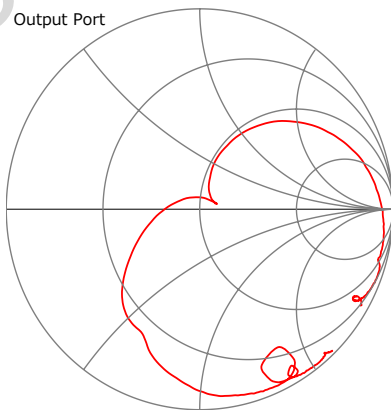
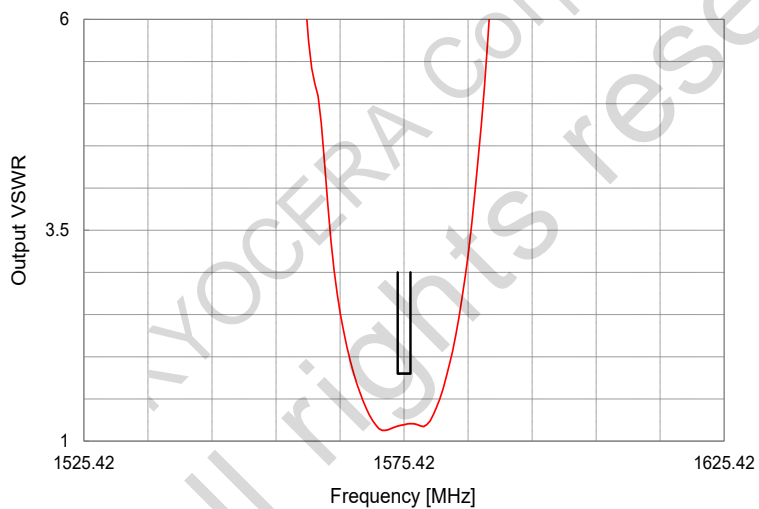
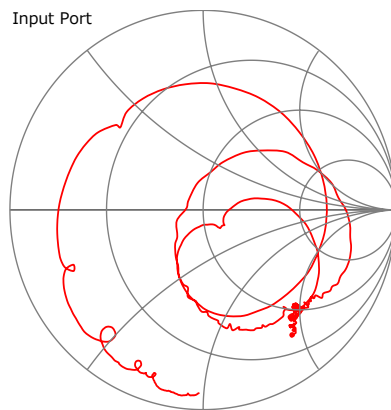
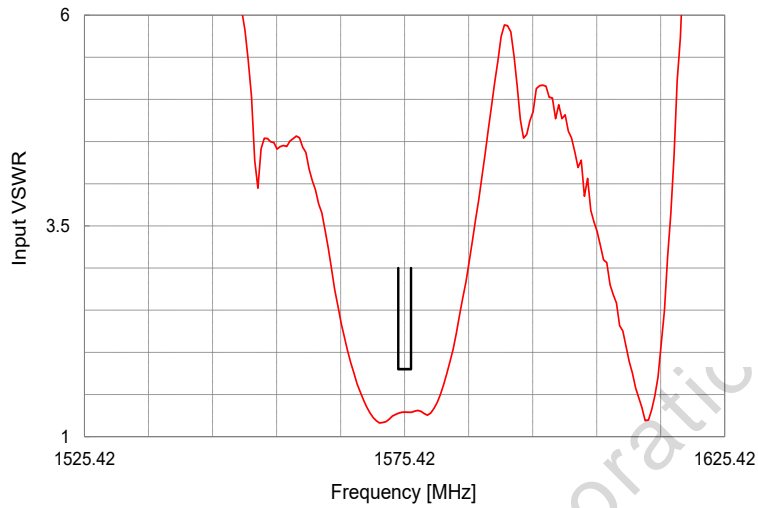

Tape & Reel Specification

[Tape]

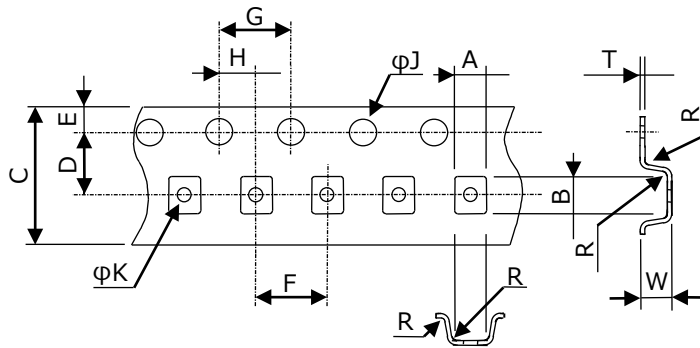

Unit : mm

| Part | Dimension |
|------|------------|
| A | 1.30±0.05 |
| B | 1.60±0.05 |
| C | 8.00±0.15 |
| D | 3.50±0.05 |
| E | 1.75±0.10 |
| F | 4.0±0.1 |
| G | 4.0±0.1 |
| H | 2.00±0.05 |
| φJ | 1.5+0.1/-0 |
| φK | 0.5±0.1 |
| R | 0.2 Max |
| W | 0.70±0.05 |
| T | 0.20±0.05 |

W : Dimension is depth of pockets.

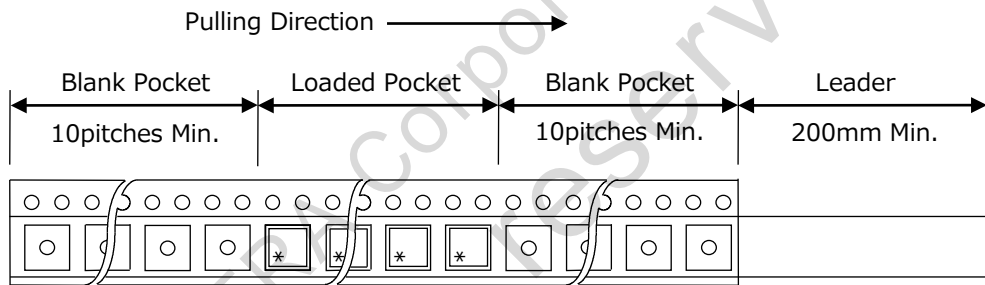

[Reel]

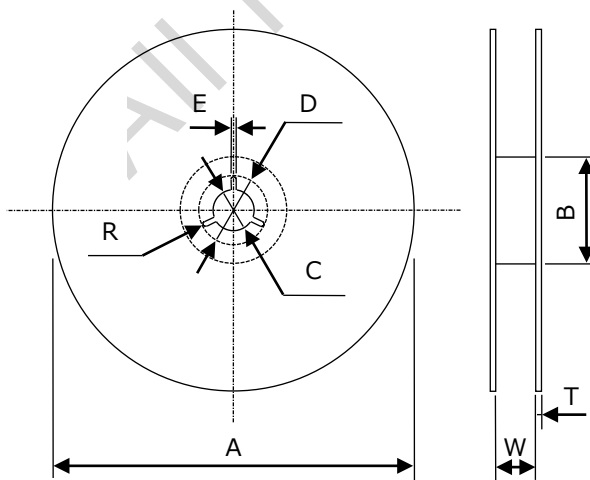

Unit : mm

| Part | Dimension |
|------|------------|
| A | 178 ± 2 |
| B | 60 ± 2 |
| C | 13.0 ± 0.2 |
| D | 21.0 ± 0.8 |
| E | 2.0 ± 0.5 |
| R | 1 |
| W | 9.5 ± 1.0 |
| T | 2.0 ± 0.2 |

Notice

1. Characteristics described in this datasheet are for references specifications shall be based on written documents agreed by each party.
2. Contents in this datasheet are subject to change without notice. It is recommended to confirm the latest information at the time of usage. Also, this datasheet is revised once a year. We may not be able to accept requests based on old datasheets.
3. Products in this datasheet are intended to be used in general electronic equipment such as office equipment, audio and visual equipment, communication equipment, measurement instrument and home appliances. It is absolutely recommended to consult with our sales representatives in advance upon planning to use our products in applications which require extremely high quality and reliability such as aircraft and aerospace equipment, traffic systems, safety systems, power plant and medical equipment including life maintenance systems.
4. Even though we strive for improvements of quality and reliability of products, it is requested to design with enough safety margin in equipment or systems in order not to threaten human lives directly or damage human bodies or properties by an accidental result of products.
5. It is requested to design based on guaranteed specifications for such as maximum ratings, operating voltage and operating temperature. It is not the scope of our guarantee for unsatisfactory results due to misuse or inadequate usage of products in the datasheet.
6. Operation summaries and circuit examples in this datasheet are intended to explain typical operation and usage of the product. It is recommended to perform circuit and assembly design considering surrounding conditions upon using products in this datasheet.
7. Technical information described in this datasheet is meant to explain typical operations and applications of products, and it is not intended to guarantee or license intellectual properties or other industrial rights of the third party or Kyocera.
8. Trademarks, logos and brand names used in this datasheet are owned by Kyocera or the corresponding third party.
9. Certain products in this datasheet are subject to the Foreign Exchange and Foreign Trade Control Act of Japan, and require the license from Japanese Government upon exporting the restricted products and technical information under the law. Besides, it is requested not to use products and technical information in the datasheet for the development and/or manufacture of weapons of mass destruction or other conventional weapons, nor to provide them to any third party with the possibility of having such purposes.
10. It is prohibited to reprint and reproduce a part or whole of this datasheet without permission.