

Datasheet of SAW Diplexer

1109 GNSS

For GPS(L1) _GLONASS(G1)

For GPS(L5) _GALILEO(E5b) _GPS(L2)

KYOCERA Part No. : SF11-1197Y6UUA1

KYOCERA Corporation
All rights reserved

Rating

Items		Rating	Unit	Note
Operating Temperature Range		-40 to +85	deg.C	
Storage Temperature Range		-40 to +85	deg.C	
Max Input Power In Band		15	dBm	5,000Hours, Ta=50deg.C ,CW
ESD Level	Machine Model	50	Volt	Complied to JESD22-A115
Input Impedance		50//5.1nH	ohm	Unbalance
Output Impedance - Lch		50//9.4nH	ohm	Unbalance
Output Impedance - Hch		50	ohm	Unbalance

Dimensions

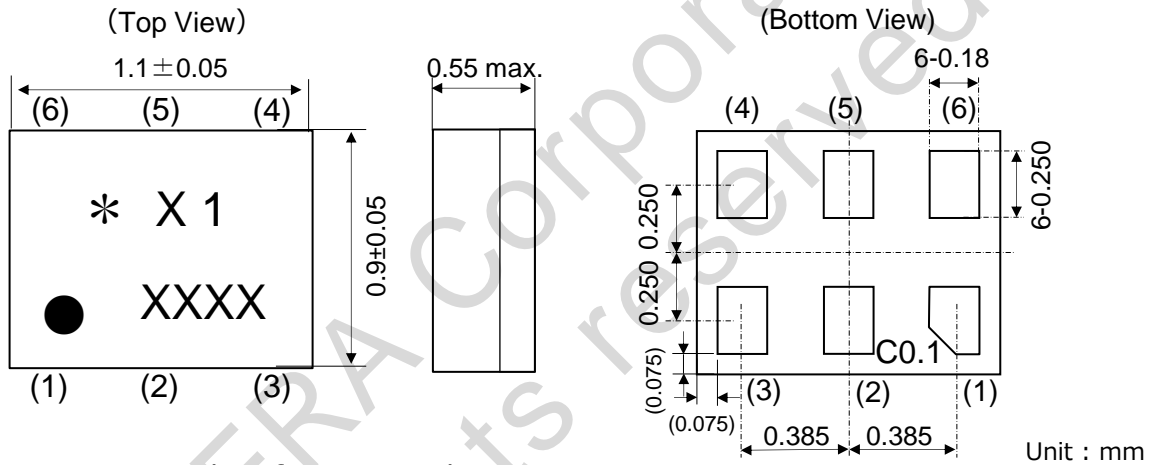

- * : Identification mark
- X1 : Identification no.
- : Index mark of pin 1
- XXXX : Production code

Pin No.	Function
(1)	GND
(2)	Input
(3)	GND
(4)	Lch Output
(5)	GND
(6)	Hch Output

Recommendable Land Pattern

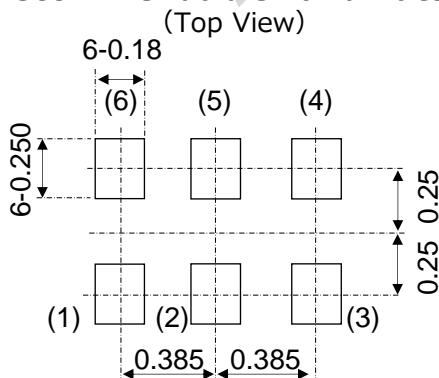

Measurement Circuit

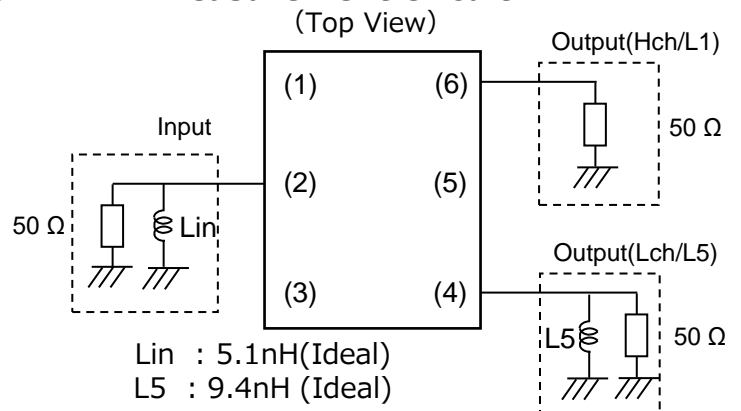

Electrical Characteristics

Items	Frequency[MHz]	Unit	Specification			Note		
			min	typ	max			
L1 1.5GHz	Insertion Loss	1559.05 - 1563.15	dB	-	1.5	2.3	B1	
		1574.39 - 1576.45	dB	-	1.4	2.0	L1	
		1597.55 - 1605.89	dB	-	1.7	2.3	G1	
	VSWR	Input	1559.05 - 1605.89	-	-	1.4	2.2	
		Output	1559.05 - 1605.89	-	-	1.6	2.2	
	GDT Ripple Deviation	1597.55 - 1605.89	ns	-	2.4	9.0		
	Attenuation	10 - 699	dB	40	44	-		
		703 - 798	dB	38	42	-		
		814 - 915	dB	36	40	-	B26/ B8Tx	
		1427 - 1463	dB	35	44	-	B11/ B21	
		1710 - 1797	dB	42	47	-	B3Tx	
		1850 - 1980	dB	40	46	-	B2Tx	
		2010 - 2570	dB	40	46	-	B34Tx/ B30Tx/ 2.4G ISM/ B7Tx	
		3300 - 4200	dB	30	37	-	N78, N77	
4400 - 5000	dB	27	37	-	N79			
5150 - 5950	dB	25	37	-	5G ISM			
L5 1.1GHz	Insertion Loss	1166.22 - 1186.68	dB	-	0.8	1.8	L5	
		1196.91 - 1217.37	dB	-	1.2	1.8	E5b	
		1226.58 - 1228.62	dB	-	1.6	2.1	L2	
	VSWR	Input	1166.22 - 1186.68	-	-	1.4	2.1	
			1196.91 - 1217.37	-	-	1.6	2.1	
			1226.58 - 1228.62	-	-	1.2	2.1	
		Output	1166.22 - 1186.68	-	-	1.4	2.1	
			1196.91 - 1217.37	-	-	1.5	2.1	
			1226.58 - 1228.62	-	-	1.2	2.1	
	GDT Ripple Deviation	1166.22 - 1186.68	ns	-	5.5	25.0		
		1196.91 - 1217.37	ns	-	3.2	25.0		
		1226.58 - 1228.62	ns	-	6.2	25.0		
	Attenuation	650 - 850	dB	30	38	-		
		850 - 950	dB	25	33	-		
		1427 - 1463	dB	25	30	-	B11/ B21	
		1626 - 1661	dB	20	23	-		
		1710 - 2200	dB	26	33	-	B3/ B2	
2300 - 2690		dB	28	33	-			
3300 - 4200		dB	25	31	-	N78, N77		
4400 - 5000		dB	25	31	-	N79		
5150 - 5950	dB	18	28	-	5G ISM			

Electrical Characteristics L1(1.5GHz)

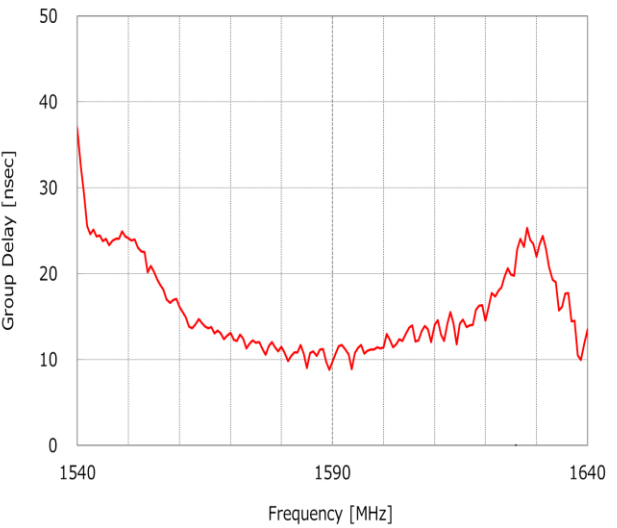
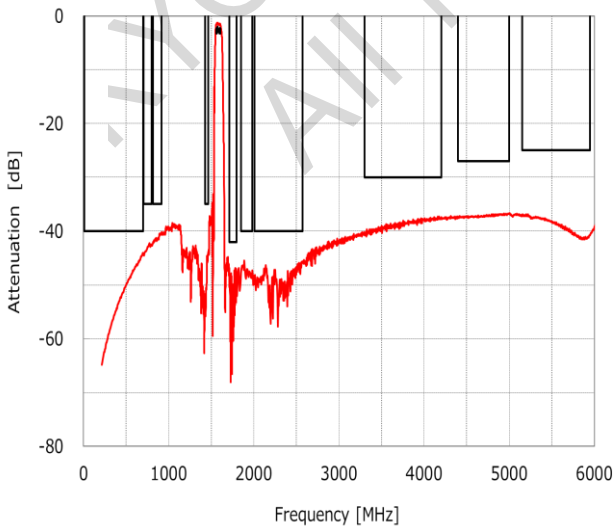
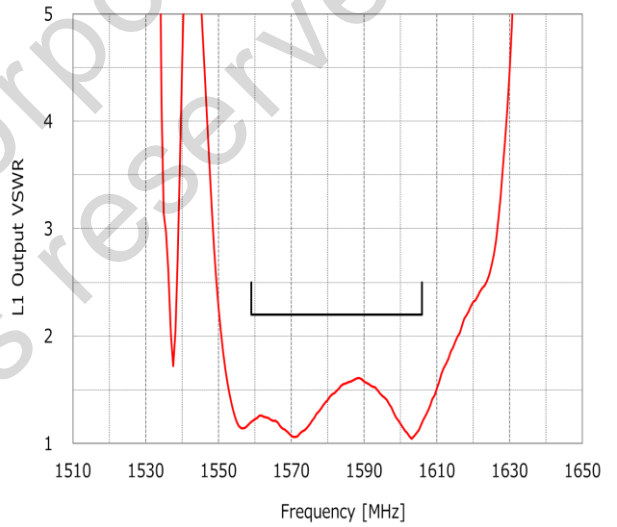
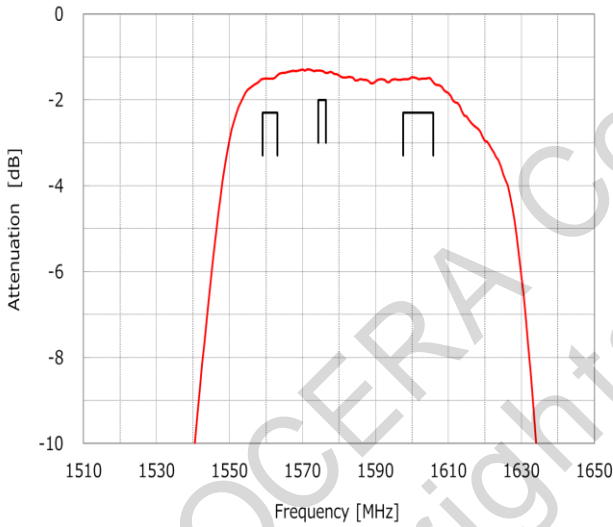
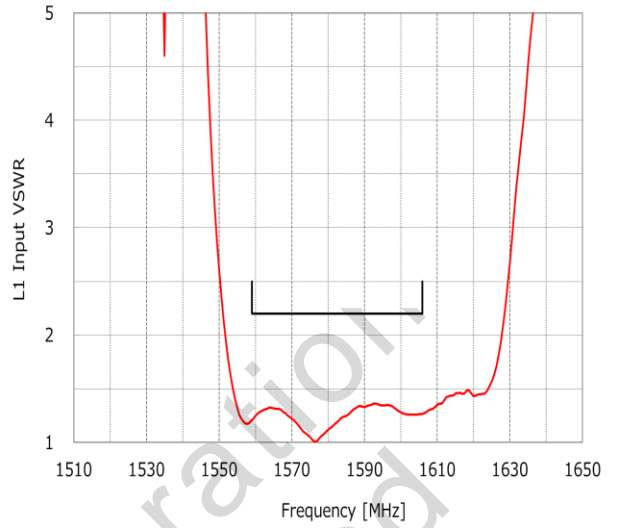
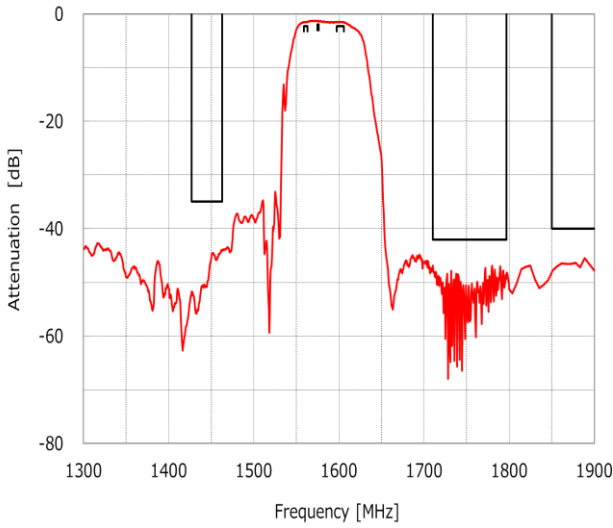

Electrical Characteristics L5(1.1GHz)

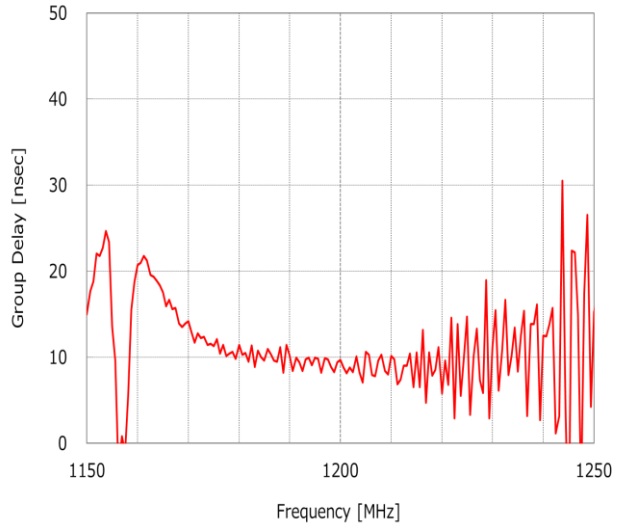
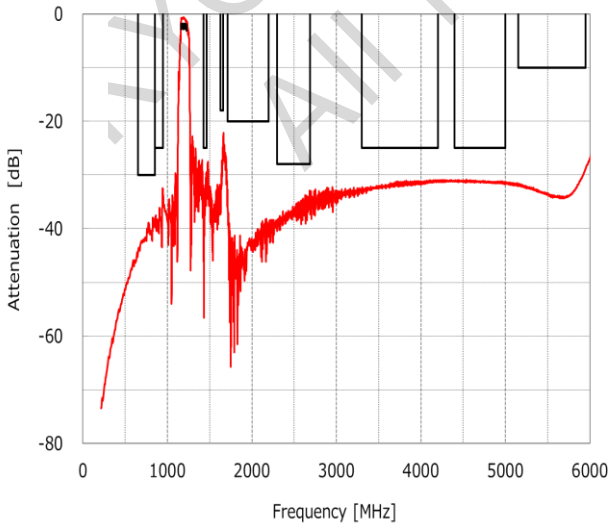
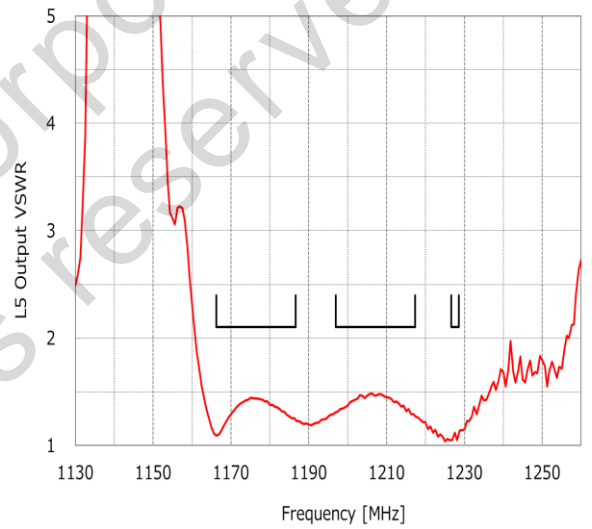
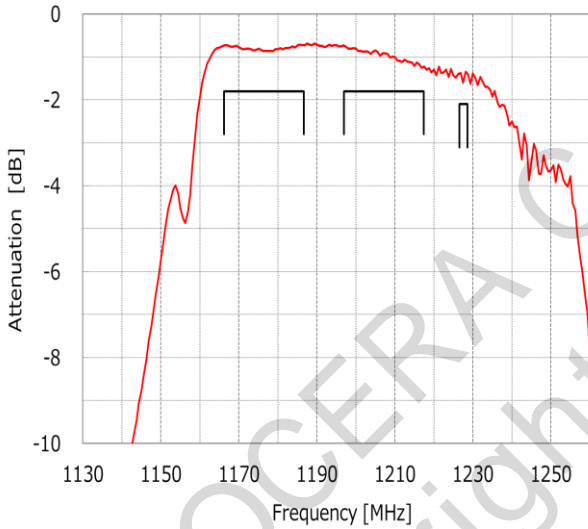
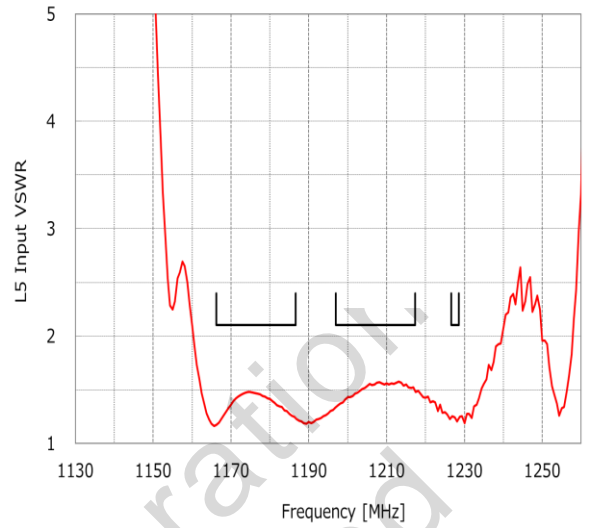
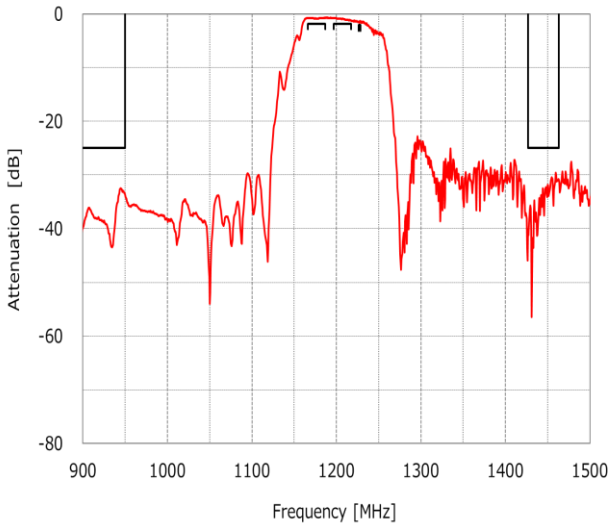

Tape & Reel Specification

[Tape]

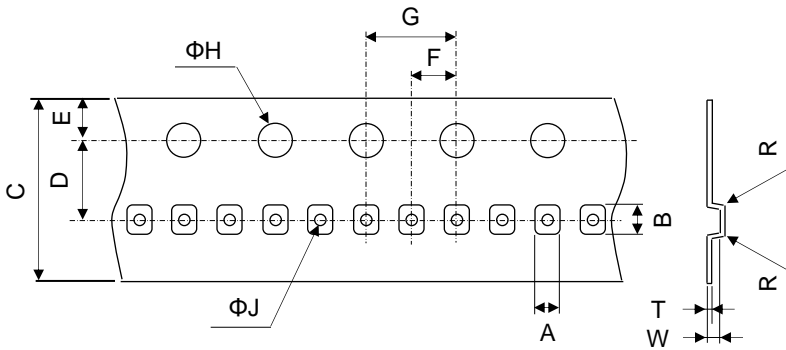

Unit : mm

Part	Dimension
A	1.1±0.05
B	1.3±0.05
C	8.0±0.1
D	3.5±0.05
E	1.75±0.1
F	2.0±0.05
G	4.0±0.05
φH	1.5+0.1/-0
φJ	0.50±0.05
R	0.1 Max
W	0.60±0.05
T	0.20+0.03/-0.02

W : Dimension is depth of pockets.

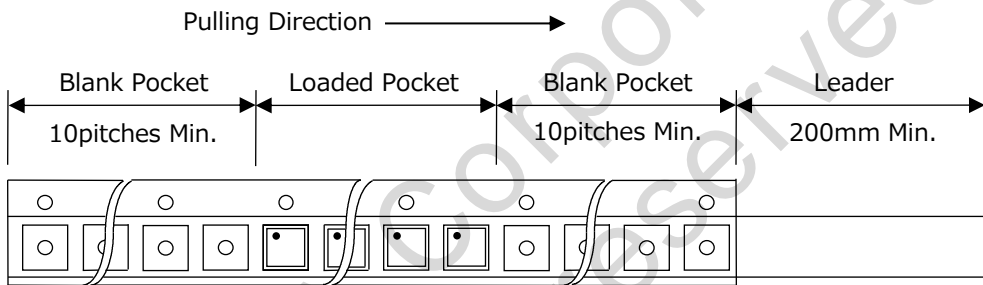

[Reel]

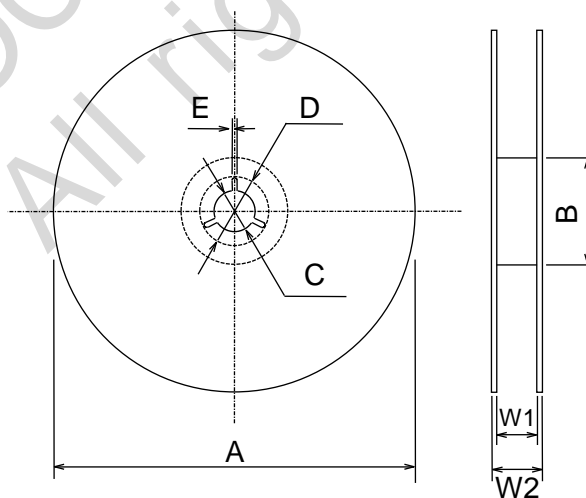

Part	A	B	C	D	Unit : mm
Dimension	180 +0/-1.5	60 +1.0/-0	13 ± 0.2	21 ± 0.8	
Part	E	W1	W2		
Dimension	2 ± 0.5	9.0 +1.0/-0	11.4 ± 1.0		

Notice

1. Characteristics described in this datasheet are for references specifications shall be based on written documents agreed by each party.
2. Contents in this datasheet are subject to change without notice. It is recommended to confirm the latest information at the time of usage. Also, this datasheet is revised once a year. We may not be able to accept requests based on old datasheets.
3. Products in this datasheet are intended to be used in general electronic equipment such as office equipment, audio and visual equipment, communication equipment, measurement instrument and home appliances. It is absolutely recommended to consult with our sales representatives in advance upon planning to use our products in applications which require extremely high quality and reliability such as aircraft and aerospace equipment, traffic systems, safety systems, power plant and medical equipment including life maintenance systems.
4. Even though we strive for improvements of quality and reliability of products, it is requested to design with enough safety margin in equipment or systems in order not to threaten human lives directly or damage human bodies or properties by an accidental result of products.
5. It is requested to design based on guaranteed specifications for such as maximum ratings, operating voltage and operating temperature. It is not the scope of our guarantee for unsatisfactory results due to misuse or inadequate usage of products in the datasheet.
6. Operation summaries and circuit examples in this datasheet are intended to explain typical operation and usage of the product. It is recommended to perform circuit and assembly design considering surrounding conditions upon using products in this datasheet.
7. Technical information described in this datasheet is meant to explain typical operations and applications of products, and it is not intended to guarantee or license intellectual properties or other industrial rights of the third party or Kyocera.
8. Trademarks, logos and brand names used in this datasheet are owned by Kyocera or the corresponding third party.
9. Certain products in this datasheet are subject to the Foreign Exchange and Foreign Trade Control Act of Japan, and require the license from Japanese Government upon exporting the restricted products and technical information under the law. Besides, it is requested not to use products and technical information in the datasheet for the development and/or manufacture of weapons of mass destruction or other conventional weapons, nor to provide them to any third party with the possibility of having such purposes.
10. It is prohibited to reprint and reproduce a part or whole of this datasheet without permission.