

KYOCERA SAW Duplexer
- 1814size Band1 Unbalanced-Rx -
Type Name : SD18-1950R8UBQ1

Dec., 25, 2025

KYOCERA Corporation

Corporate Electronic Components Group

Electronic Devices Division

Dimensions & Test Circuit of SAW Duplexer

■ Dimensions

■ Test Circuit

(Top View)

(Bottom View)

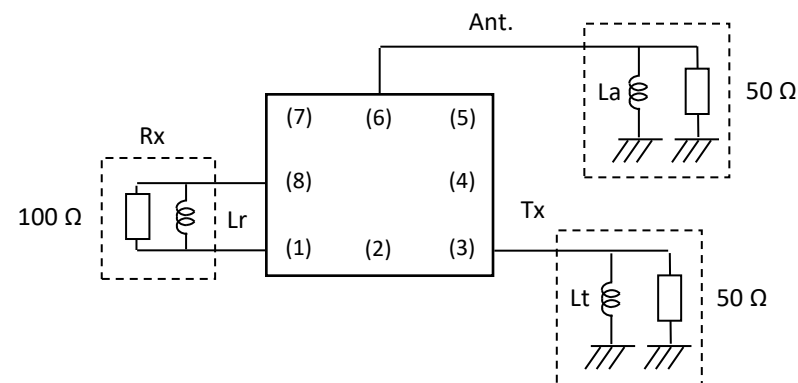
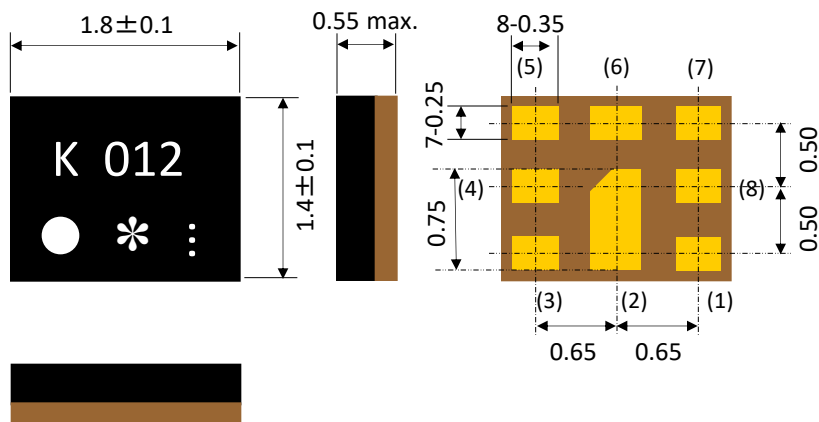

- Unit : mm
 K : KYOCERA logo
 012 : Identification no.
 ● : Index mark of pin 1
 * : Monthly code
 ⋮ : Index mark of ten days
 (∴ 1-10, ∴ 11-20, ∴ 21-31)

Pin No.	Function
(1)	Rx
(2)	GND
(3)	Tx
(4)	GND
(5)	GND
(6)	Ant.
(7)	GND
(8)	Rx

La : 2.7nH (Ideal)

Lr : 10nH (Ideal)

Lt : 7.5mH (Ideal)

Port extension (Time) : 93ps

Port extension (Loss) : 0.15dB

Characteristic table

[Tx to Ant]

Items		Frequency Range [MHz]		KYOCERA 1814 size SD18-1950R8UBQ1 Aug., 22, 2014			Unit	Notes	
				Specification					
				min.	typ.	max.			
Tx to Ant	Nominal Frequency	-		1950			MHz		
	Insertion Loss	1920.48	to 1979.52	-	1.6	2.0	dB	S21	
	Ripple (any 5MHz)	1920.48	to 1979.52	-	0.2	0.5	dB		
	VSWR	Tx	1920.48	to 1979.52	-	1.5	2.0	-	
		Ant	1920.48	to 1979.52	-	1.5	2.0	-	
	Absolute Attenuation	10	to 1574	30	43	-	dB		
		420	to 494	44	69	-	dB	450MHz Rx band	
		843	to 894	44	53	-	dB	JCDMA/CELL Rx band	
		1565.42	to 1573.374	42	43	-	dB	Wideband GPS, lower	
		1573.374	to 1577.466	42	43	-	dB	Regular GPS	
		1577.466	to 1585.42	42	43	-	dB	Wideband GPS, upper	
		1597.5515	to 1605.886	42	44	-	dB	GLONASS	
		1605.886	to 1805	25	36	-	dB		
		1805	to 1865	25	30	-	dB	Protected DCS band	
		1865	to 1880	10	30	-	dB	Protected DCS band	
		2010	to 2025	5	10	-	dB		
				(+15~+85°C)					
2110	to 2170	44	51	-	dB	IMT band			
2400	to 2500	36	42	-	dB	ISM			
2620	to 2690	20	39	-	dB	Protected 2.6GHz band			
3830	to 3970	25	33	-	dB	2fo			
5150	to 5950	18	28	-	dB	3fo			

Characteristic table

[Ant to Rx & Tx to Rx]

Items		Frequency Range [MHz]		KYOCERA 1814 size SD18-1950R8UBQ1 Aug., 22, 2014			Unit	Notes	
				Specification					
				min.	typ.	max.			
Ant to Rx	Nominal Frequency	-		2140			MHz		
	Insertion Loss	2110.48	to 2169.52	-	1.8	2.5	dB		
	Ripple (any 5MHz)	2110.48	to 2169.52	-	0.2	0.5	dB		
	Amplitude Imbalance	2110.48	to 2169.52	-1.5	-0.6/0.9	+1.5	dB		
	Phase Imbalance	2110.48	to 2169.52	-10	-6.1/1.8	+10	deg		
	VSWR	Rx	2110.48	to 2169.52	-	1.2	2.0	-	
		Ant	2110.48	to 2169.52	-	1.3	2.0	-	
	Absolute Attenuation	1	to 1920	35	55	-	dB		
		1920	to 1980	45	56	-	dB		
		1980	to 2025	15	44	-	dB		
2255		to 2400	15	43	-	dB			
2400		to 2484	30	48	-	dB			
	2484	to 6000	35	45	-	dB			
Tx to Rx	Differential Mode	1574	to 1577	40	62	-	dB		
		1920.48	to 1979.52	53	54	-	dB		
		2112.4	to 2167.6	54	57	-	dB		
		2111.25	to 2168.75	54	57	-	dB		
		3830	to 3970	20	58	-	dB		
	5750	to 5950	20	62	-	dB			
Common Mode	1920.48	to 1979.52	50	52	-	dB			
Input power			+29			dBm	5,000Hours, Ta=50deg.C, CW		
Impedance	Tx port (Unbalance)		50//7.5nH			ohm			
	Ant port (Unbalance)		50//2.7nH			ohm			
	Rx port (Balance)		100//10nH			ohm			
Package size			1.8x1.4, T=0.55max.			mm			
Operating temperature range	UMTS		-30 to +85			deg.C			
	CDMA 1X								

(*) Integrated over +/-1.92MHz around the WCDMA and +/-0.625MHz around the NCDMA channel center frequency

Typical Curve Data

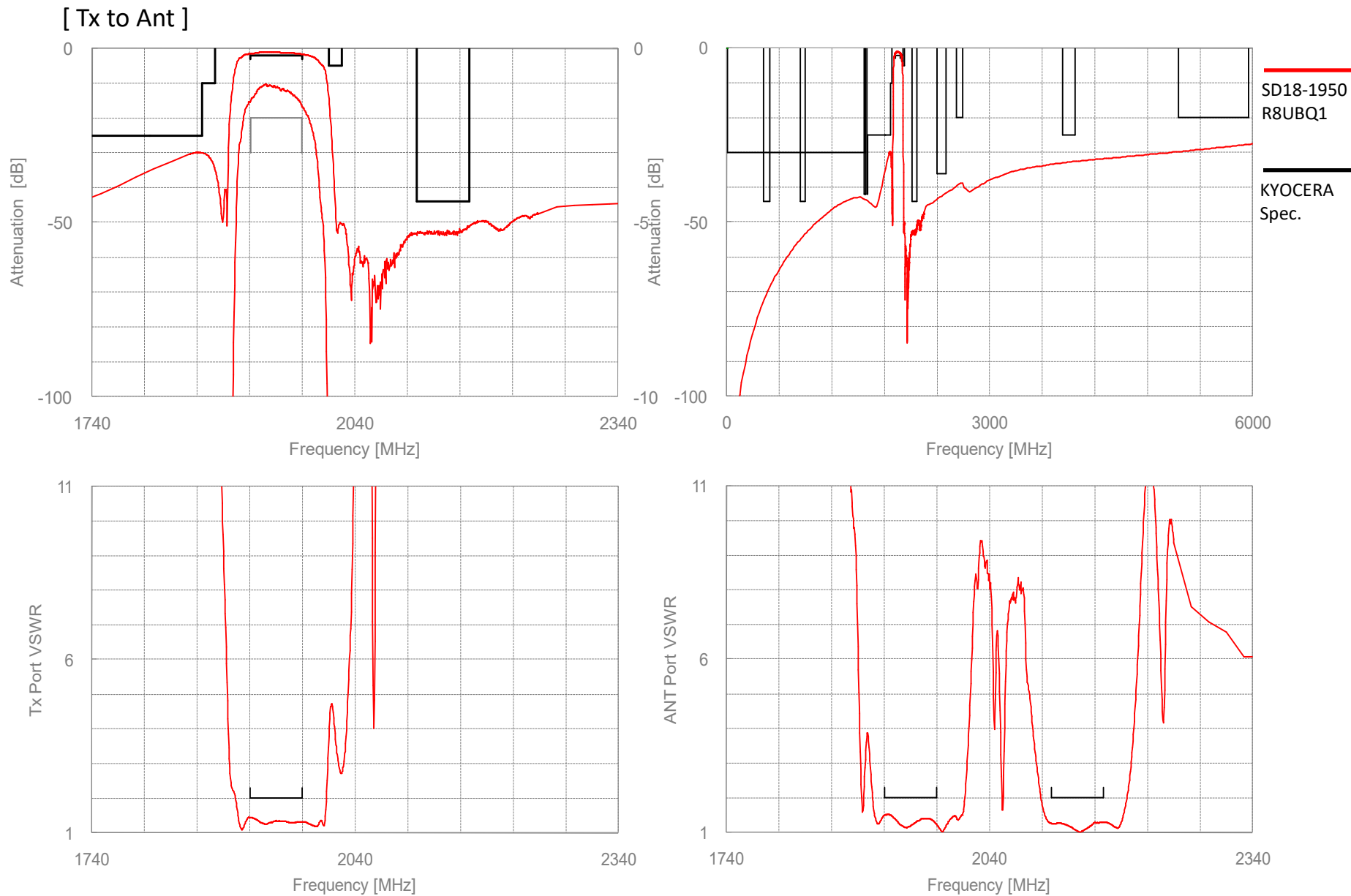

Typical Curve Data

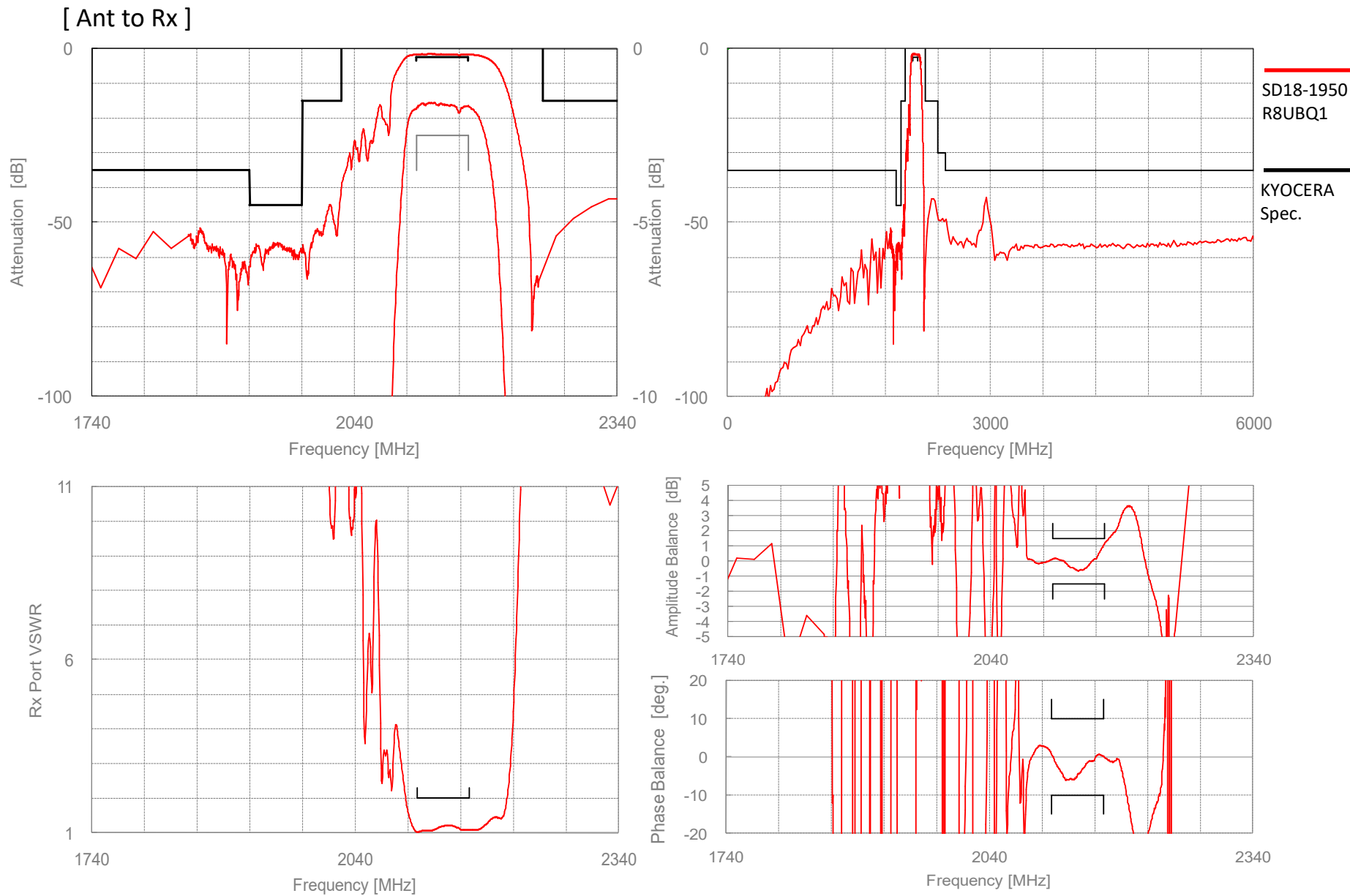

Typical Curve Data

[Tx to Rx]

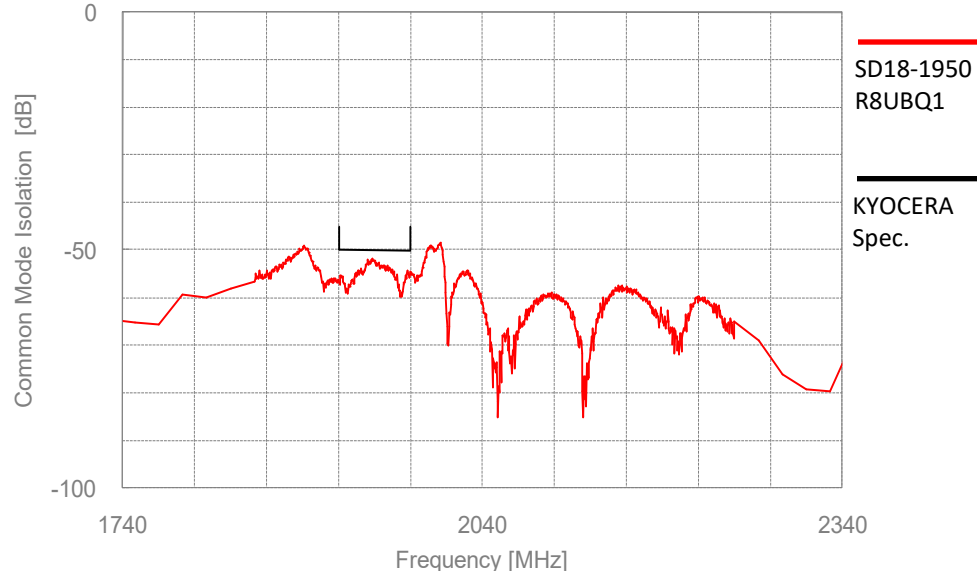
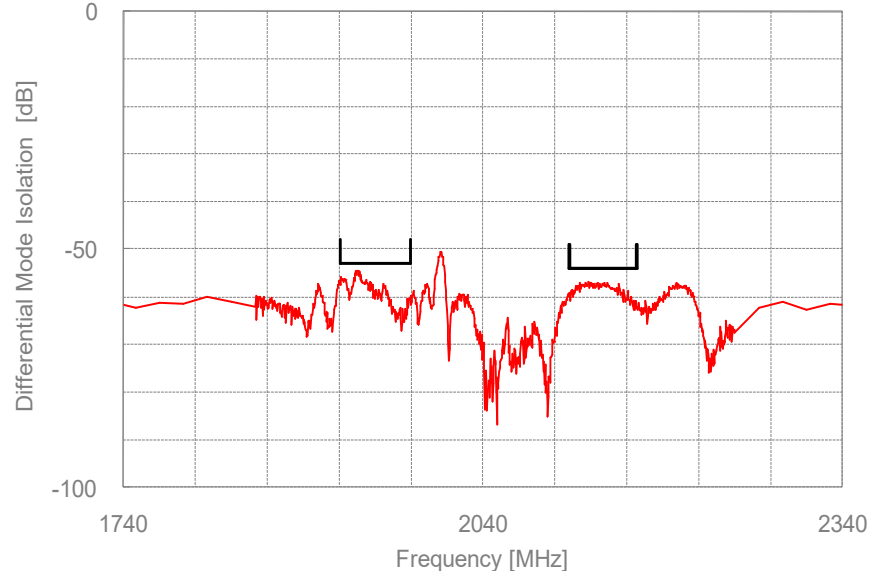

[Port impedance]

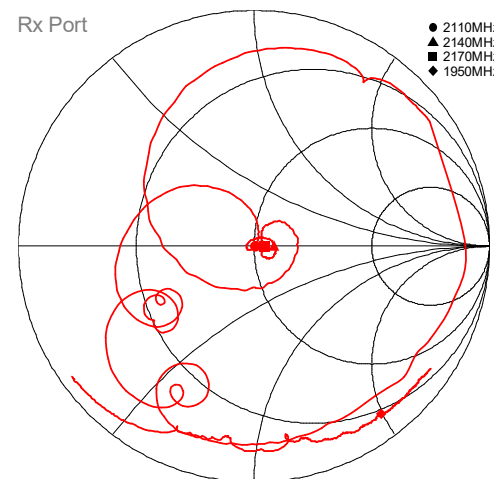
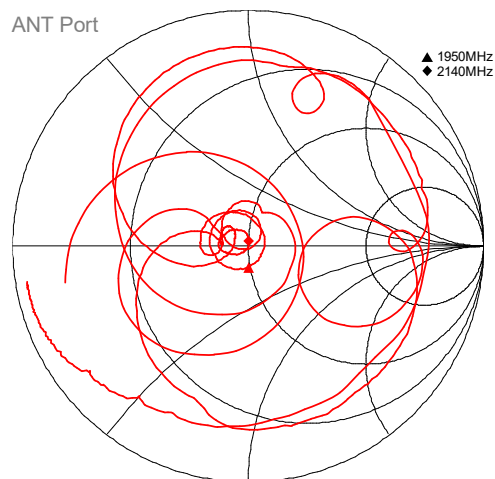
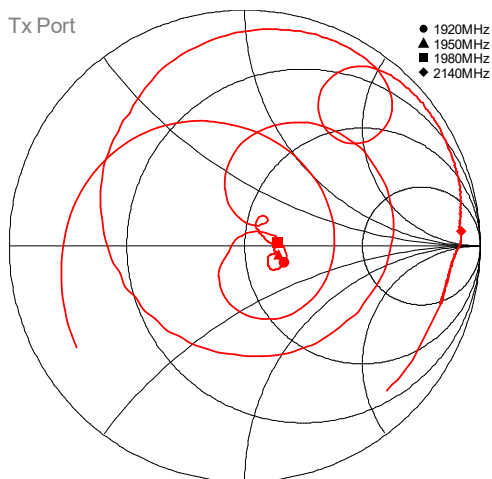

1. Characteristics described in this datasheet are for references specifications shall be based on written documents agreed by each party.
2. Contents in this datasheet are subject to change without notice. It is recommended to confirm the latest information at the time of usage. Also, this datasheet is revised once a year. We may not be able to accept requests based on old datasheets.
3. Products in this datasheet are intended to be used in general electronic equipment such as office equipment, audio and visual equipment, communication equipment, measurement instrument and home appliances. It is absolutely recommended to consult with our sales representatives in advance upon planning to use our products in applications which require extremely high quality and reliability such as aircraft and aerospace equipment, traffic systems, safety systems, power plant and medical equipment including life maintenance systems.
4. Even though we strive for improvements of quality and reliability of products, it is requested to design with enough safety margin in equipment or systems in order not to threaten human lives directly or damage human bodies or properties by an accidental result of products.
5. It is requested to design based on guaranteed specifications for such as maximum ratings, operating voltage and operating temperature. It is not the scope of our guarantee for unsatisfactory results due to misuse or inadequate usage of products in the datasheet.
6. Operation summaries and circuit examples in this datasheet are intended to explain typical operation and usage of the product. It is recommended to perform circuit and assembly design considering surrounding conditions upon using products in this datasheet.
7. Technical information described in this datasheet is meant to explain typical operations and applications of products, and it is not intended to guarantee or license intellectual properties or other industrial rights of the third party or Kyocera.
8. Trademarks, logos and brand names used in this datasheet are owned by Kyocera or the corresponding third party.
9. Certain products in this datasheet are subject to the Foreign Exchange and Foreign Trade Control Act of Japan, and require the license from Japanese Government upon exporting the restricted products and technical information under the law. Besides, it is requested not to use products and technical information in the datasheet for the development and/or manufacture of weapons of mass destruction or other conventional weapons, nor to provide them to any third party with the possibility of having such purposes.
10. It is prohibited to reprint and reproduce a part or whole of this datasheet without permission.