

Datasheet of SAW Duplexer 1814 Band2 Unbalanced

KYOCERA Part No. : SD18 1880R8UUC1

KYOCERA Corporation
All rights reserved

Rating

Items	Rating	Unit	Note
Operating Temperature Range	-30 to +85	deg.C	
Storage Temperature Range	-40 to +85	deg.C	
Max Input Power (Tx port)	+30	dBm	5,000hours, Ta=50deg.C, CW
Tx Port Nominal Impedance	50	ohm	Unbalance
Ant. Port Nominal Impedance	50//3.6nH	ohm	Unbalance
Rx Port Nominal Impedance	50	ohm	Unbalance

Dimensions

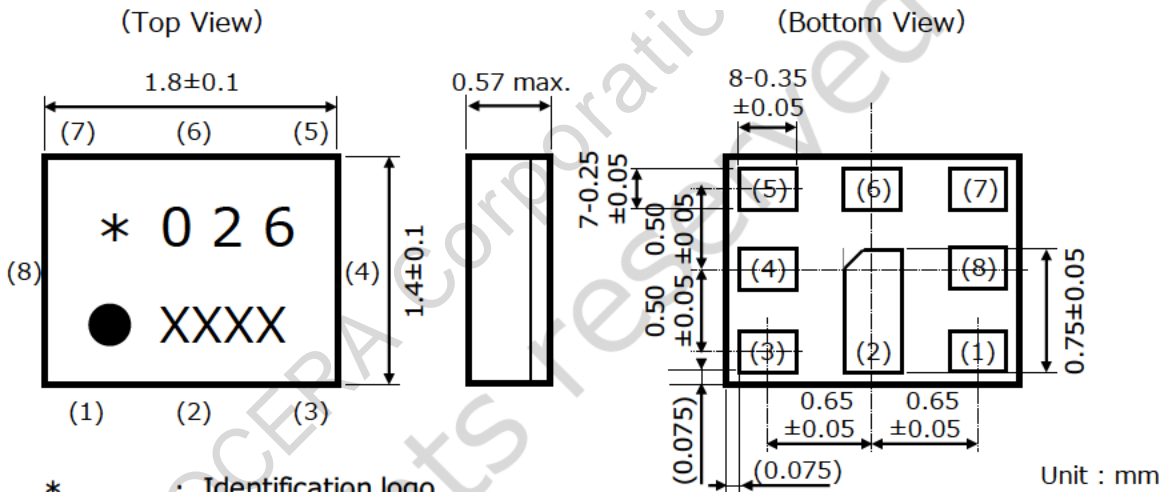

- * : Identification logo
- 026 : Identification no.
- : Index mark of pin 1
- XXXX : Production code

Pin No.	Function
(1)	Rx
(3)	Tx
(6)	Ant.
Others	GND

Recommendable Land Pattern

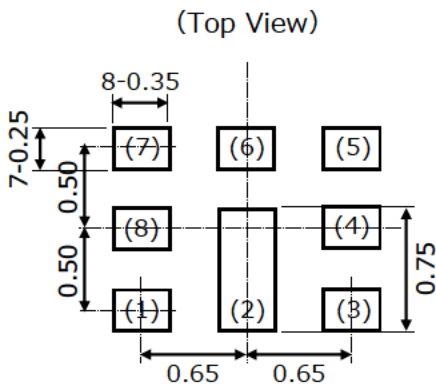

Measurement Circuit

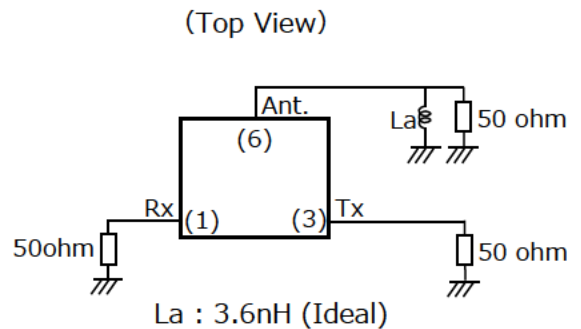

Electrical Characteristics

Items		Frequency (MHz)		Characteristics			Unit	Note	
				min.	typ.	max.			
Tx to Ant	Nominal Center Frequency	-		1880			MHz		
	Insertion Loss	1852.4	to 1907.6	-	1.6	2.4	dBint*1		
		1851.25	to 1908.75	-	1.7	2.5	dBint*2		
	Ripple (any 5MHz)	1850.48	to 1909.52	-	0.4	1.8	dB		
	VSWR	Tx	1850.48	to 1909.52	-	1.5	2.1	-	
		Ant	1850.48	to 1909.52	-	1.5	2.1	-	
	Absolute Attenuation	10	to 728	30	52	-	dB		
		704	to 716	30	53	-	dB		
		728	to 764	44	52	-	dB		
		777	to 787	30	51	-	dB		
		869	to 894	44	49	-	dB		
		1226	to 1250	41	46	-	dB		
		1559	to 1563	43	51	-	dB		
		1565.42	to 1573.374	43	51	-	dB		
		1573.374	to 1577.466	43	52	-	dB		
		1577.466	to 1585.42	43	52	-	dB		
		1597.5515	to 1605.886	43	51	-	dB		
		1605.866	to 1680	30	44	-	dB		
		1932.4	to 1987.6	48	54	-	dBint*1		
		1931.25	to 1988.75	44	5	-	dBint*2		
2010		to 2025	2	49	-	dB	+15 to +85deg.C		
2110		to 2155	42	46	-	dB			
2350		to 2360	38	40	-	dB			
2400	to 2500	35	39	-	dB				
3700	to 3820	25	31	-	dB				
4900	to 5850	20	24	-	dB				
5254	to 5 55	20	26	-	dB				
5520	to 5845	20	24	-	dB				
5540	to 5950	20	24	-	dB				
Ant to Rx	Nominal Center Frequency	-		1960			MHz		
	Insertion Loss	1932.4	to 1987.6	-	2.3	3.5	dBint*1		
		1931.25	to 1988.75	-	2.4	3.9	dBint*2		
	Ripple (any 5MHz)	1930.48	to 1989.52	-	0.5	2.5	dB		
	VSWR	Rx	1930.48	to 1989.52	-	1.5	2.1	-	
		Ant	930.48	to 1989.52	-	1.4	2.1	-	
	Absolute Attenuation	0.2	to 1850	43	47	-	dB		
		80		50	98	-	dB		
		699	to 716	40	60	-	dB		
		777	to 787	40	58	-	dB		
		824	to 849	40	57	-	dB		
		1770	to 1830	40	49	-	dB		
		1852.4	to 1907.6	48	56	-	dBint*1		
		1851.25	to 1908.75	47	56	-	dBint*2		
		1910	to 1915	15	42	-	dB		
		2005	to 2050	2	10	-	dB		
		2050	to 2075	25	31	-	dB		
2075		to 6000	36	44	-	dB			
2305		to 2315	40	45	-	dB			
2400		to 2500	40	46	-	dB			
3780		to 3900	40	59	-	dB			
3860	to 3980	40	60	-	dB				
4900	to 5950	40	68	-	dB				
5610	to 5845	48	69	-	dB				
5630	to 5810	40	69	-	dB				
5790	to 5970	40	68	-	dB				
Tx to Rx	Isolation	1574	to 1577	40	69	-	dB		
		1852.4	to 1907.6	53	57	-	dBint*1		
		1851.25	to 1908.75	52	57	-	dBint*2		
		1932.4	to 1987.6	51	56	-	dBint*1		
		1931.25	to 1988.75	48	56	-	dBint*2		
		3700	to 3820	20	55	-	dB		
5550	to 5850	20	49	-	dB				

dBint*1 : Integrated calculation, WCDMA Modulation (3.84MHz)

dBint*2 : Integrated calculation, NCDMA Modulation (1.23MHz)

Electrical Characteristics

[Tx to Ant]

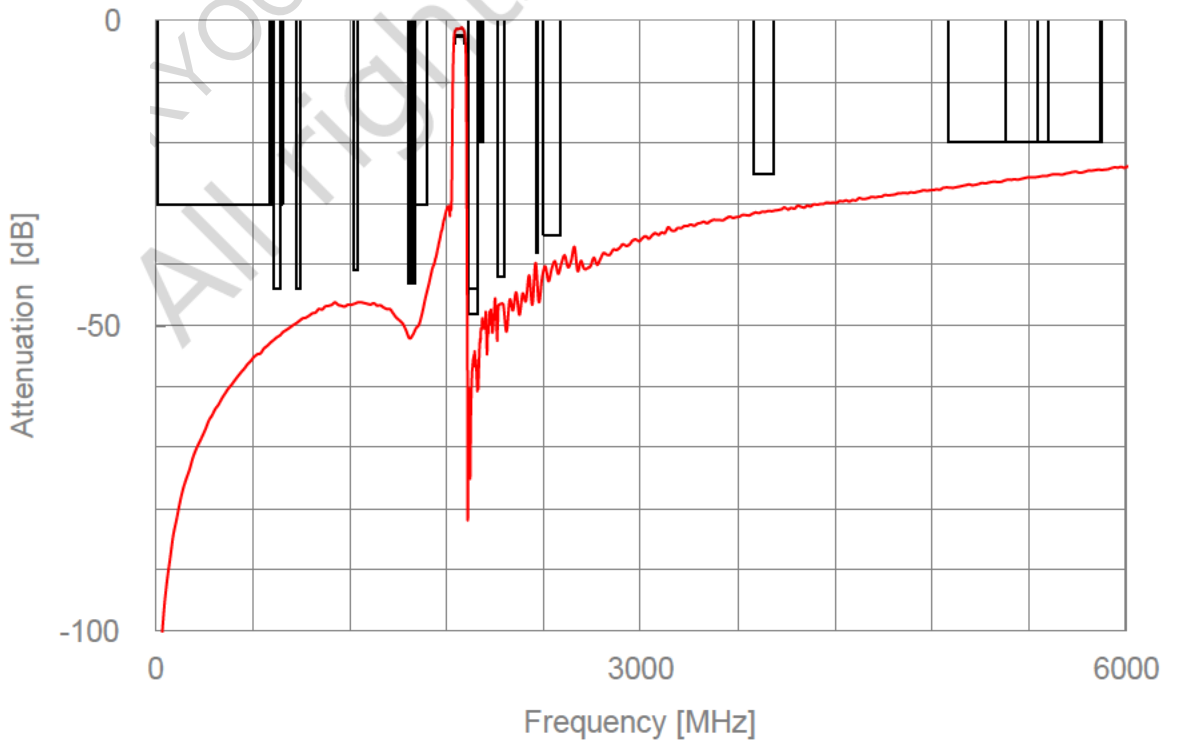
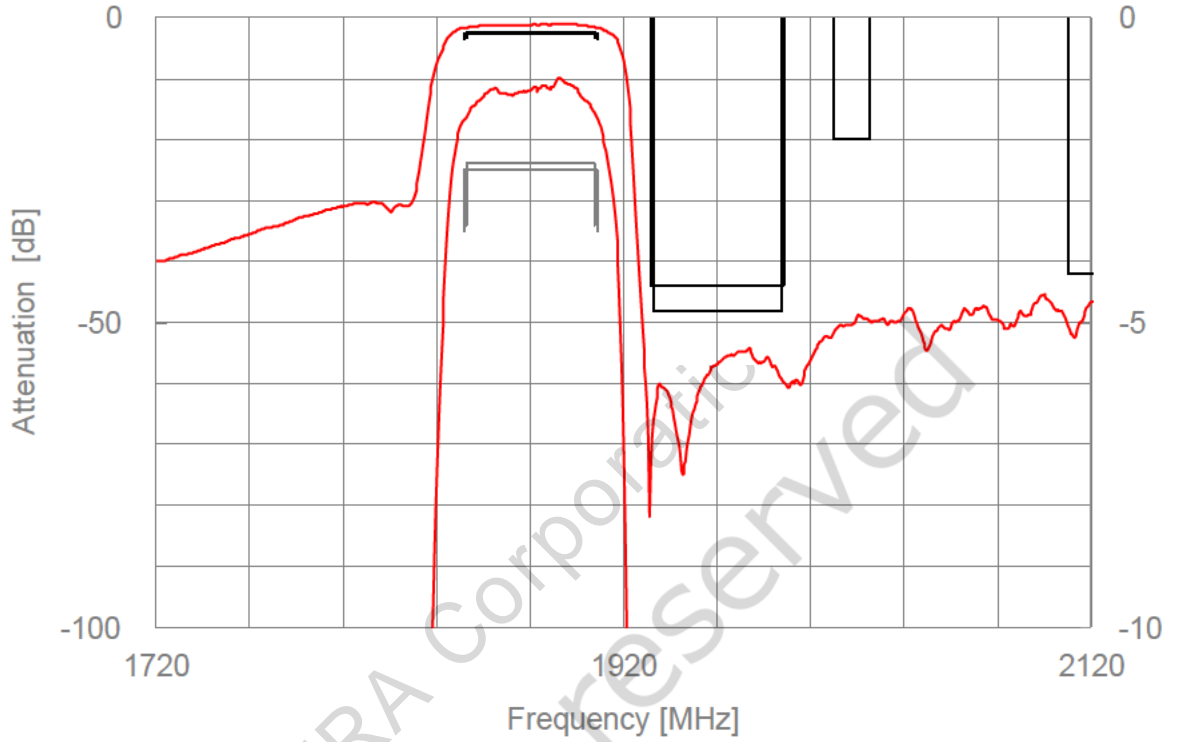

Electrical Characteristics

[Ant to Rx]

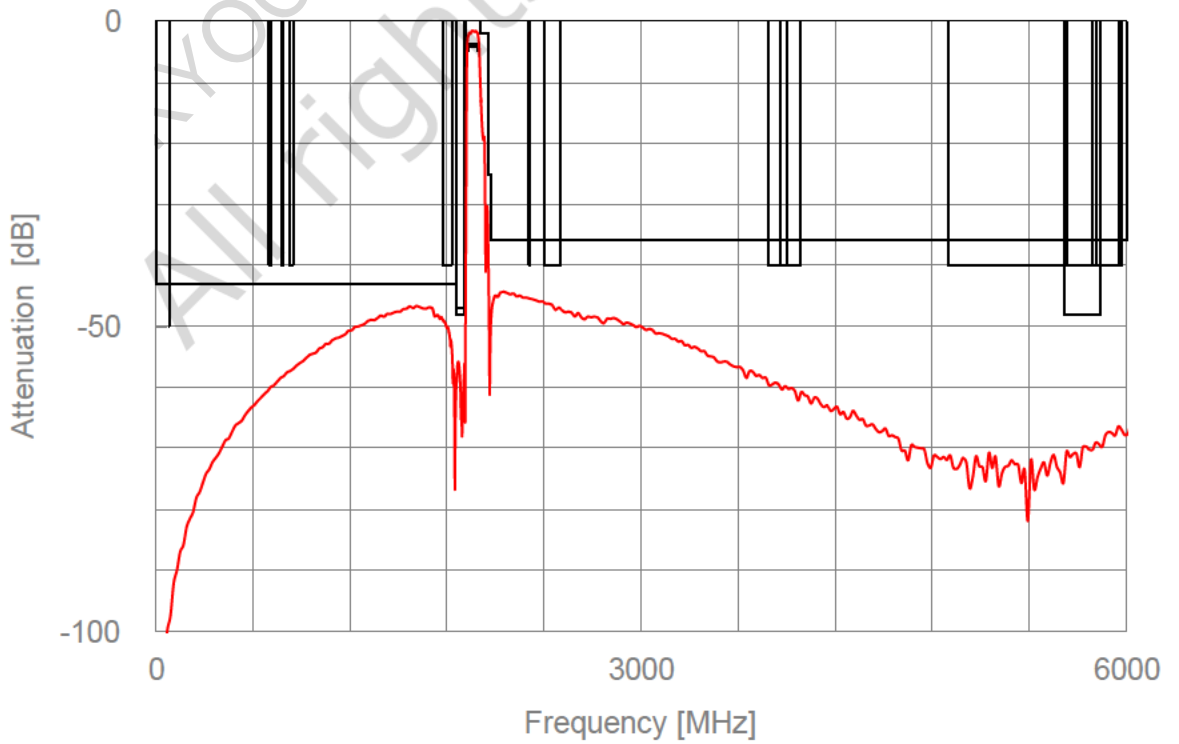
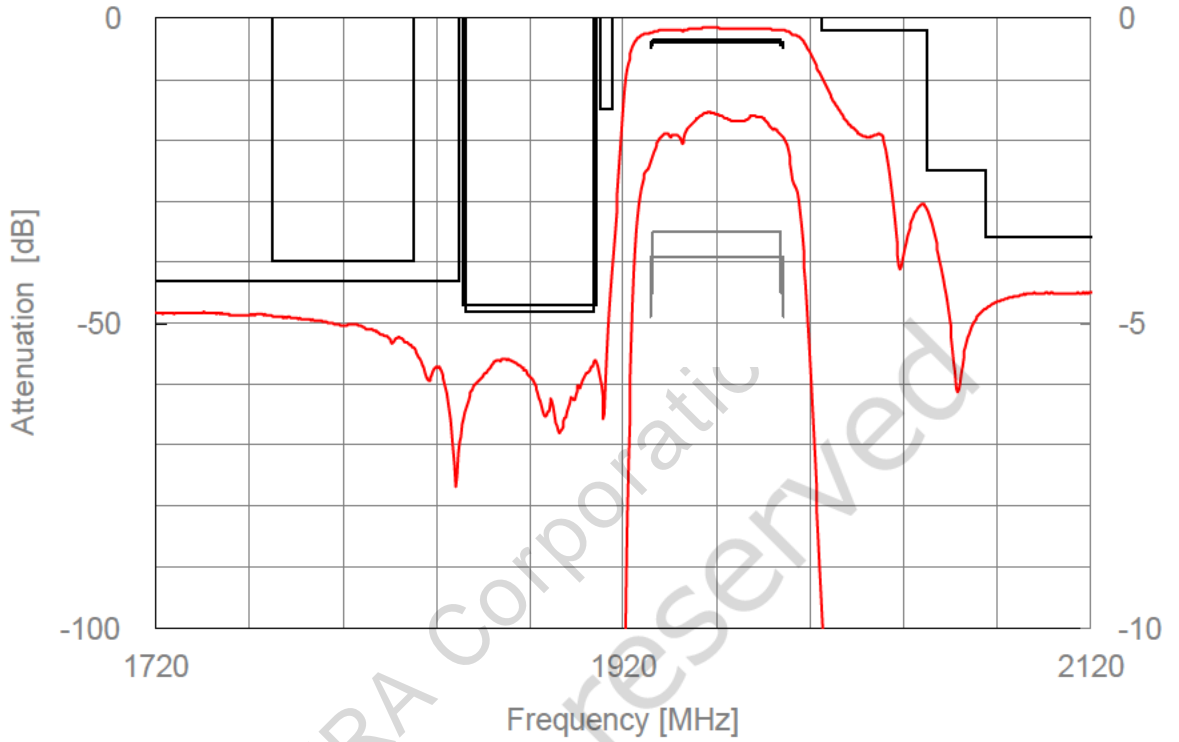

Electrical Characteristics

[Tx to Rx]

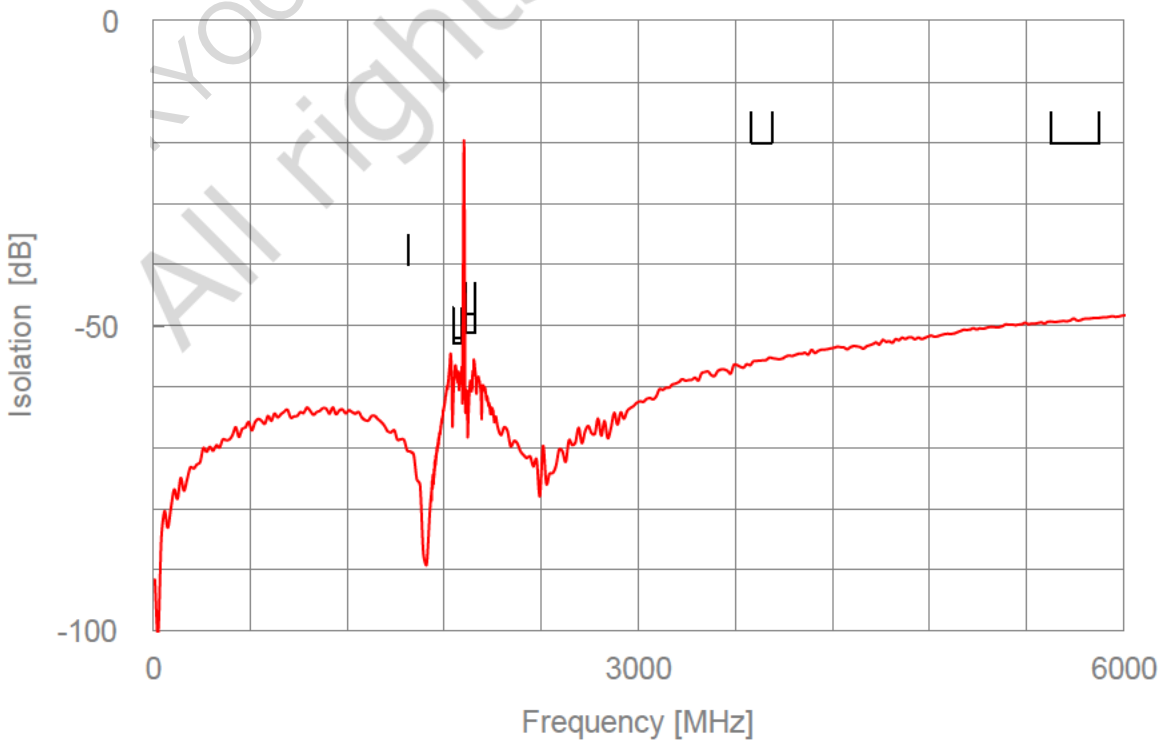
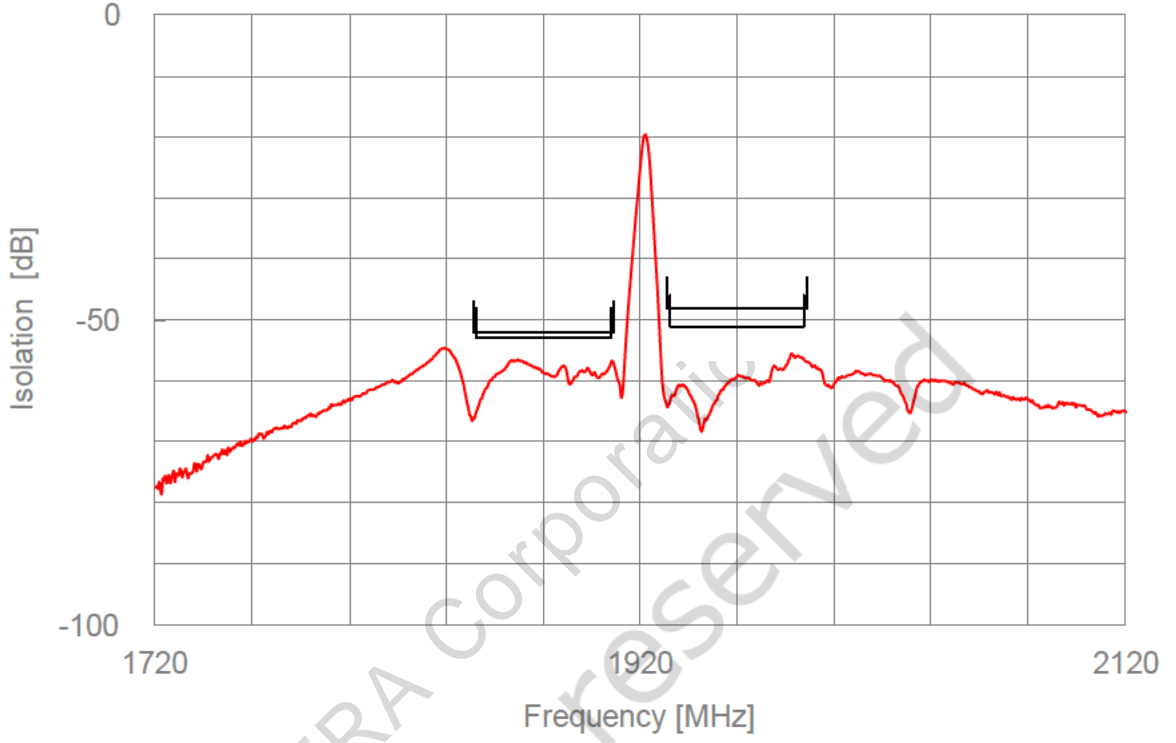

Electrical Characteristics

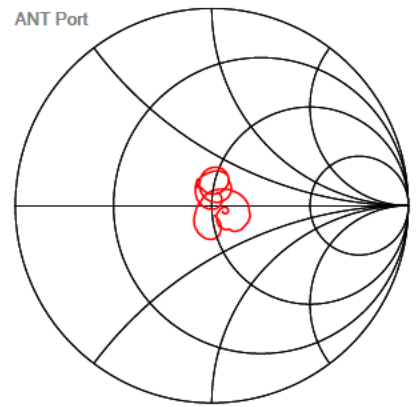
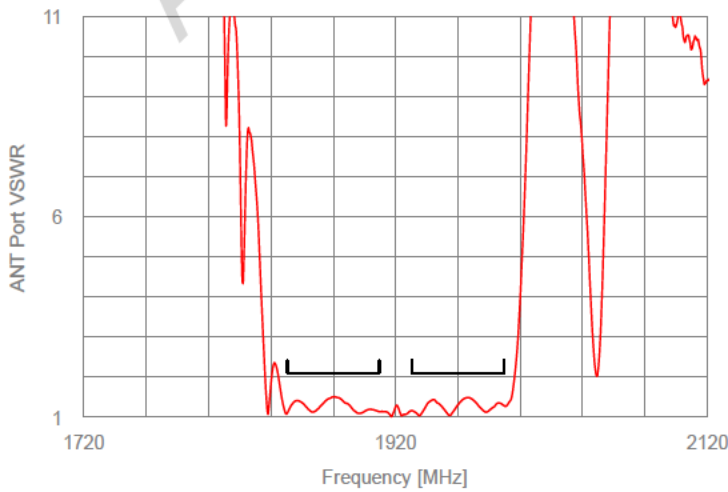
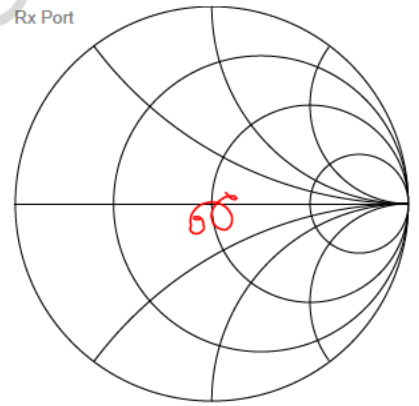
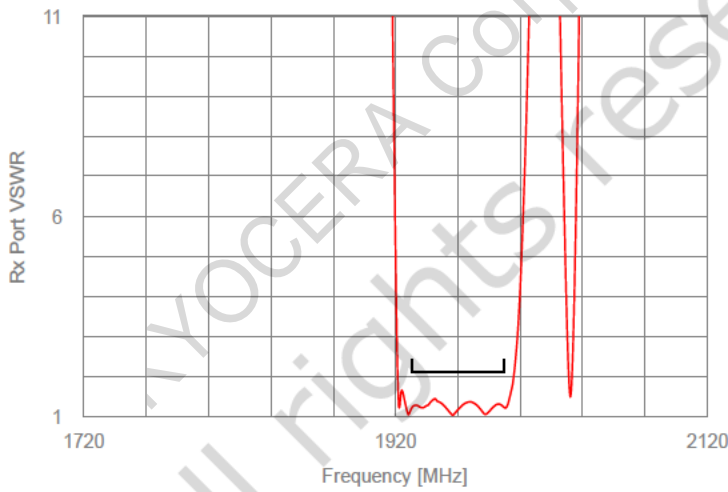
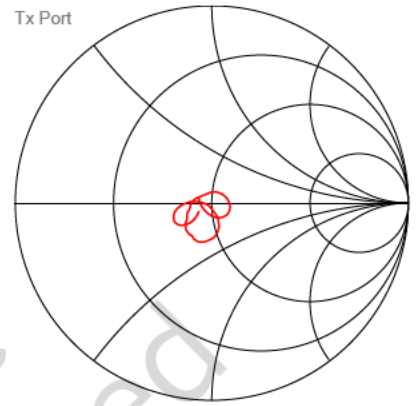
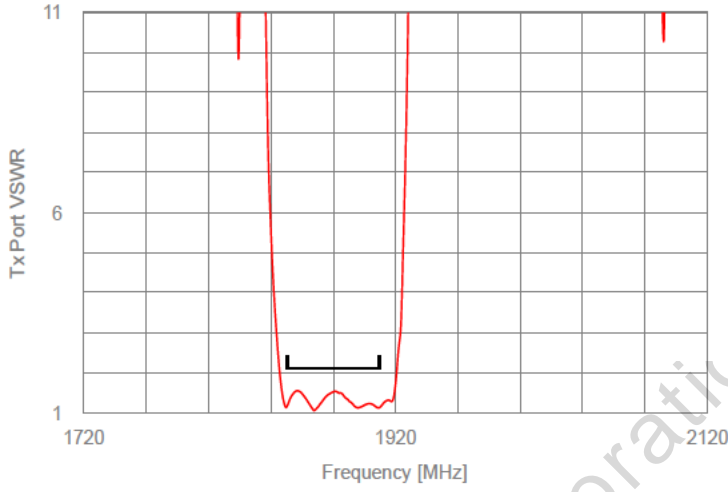

Tape & Reel Specification

[Tape]

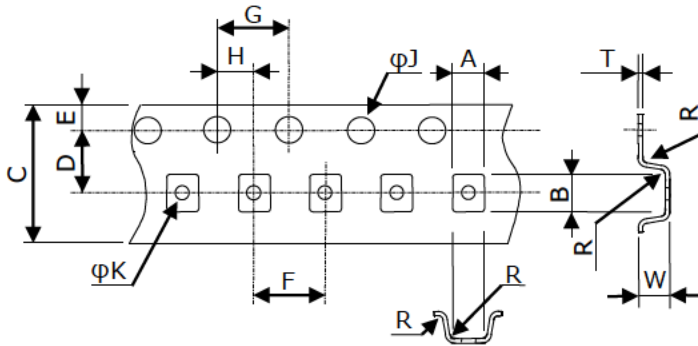

Unit : mm

Part	Dimension
A	1.7±0.1
B	2.05±0.10
C	8.0±0.2
D	3.50±0.05
E	1.75±0.10
F	4.0±0.1
G	4.0±0.1
H	2.00±0.05
φJ	1.5+0.1/-0
φK	0.80±0.05
R	0.2 Max
W	0.7±0.1
T	0.20±0.05

W : Dimension is depth of pockets.

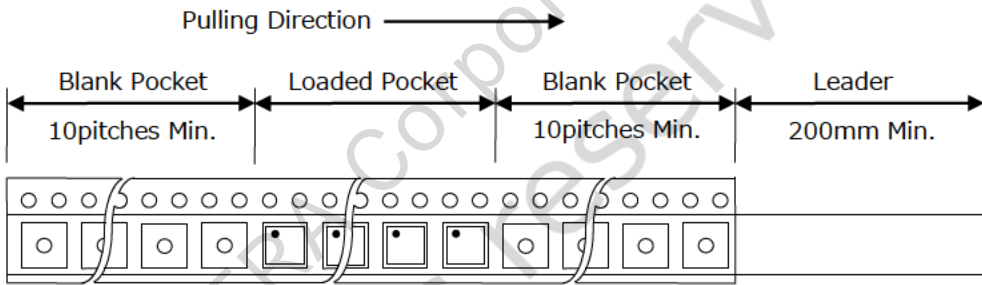

[Reel]

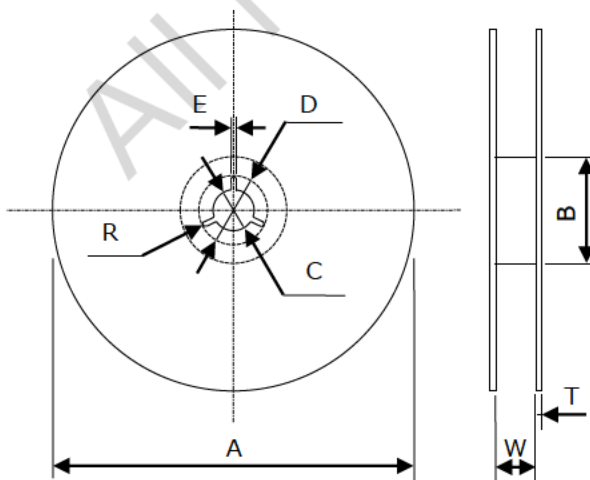

Unit : mm

Part	Dimension
A	178 ± 2
B	60 ± 2
C	13.0 ± 0.2
D	21.0 ± 0.8
E	2.0 ± 0.5
R	1
W	9.5 ± 1.0
T	2.0 ± 0.2

Notice

1. Characteristics described in this datasheet are for references specifications shall be based on written documents agreed by each party.
2. Contents in this datasheet are subject to change without notice. It is recommended to confirm the latest information at the time of usage. Also, this datasheet is revised once a year. We may not be able to accept requests based on old datasheets.
3. Products in this datasheet are intended to be used in general electronic equipment such as office equipment, audio and visual equipment, communication equipment, measurement instrument and home appliances. It is absolutely recommended to consult with our sales representatives in advance upon planning to use our products in applications which require extremely high quality and reliability such as aircraft and aerospace equipment, traffic systems, safety systems, power plant and medical equipment including life maintenance systems.
4. Even though we strive for improvements of quality and reliability of products, it is requested to design with enough safety margin in equipment or systems in order not to threaten human lives directly or damage human bodies or properties by an accidental result of products.
5. It is requested to design based on guaranteed specifications for such as maximum ratings, operating voltage and operating temperature. It is not the scope of our guarantee for unsatisfactory results due to misuse or inadequate usage of products in the datasheet.
6. Operation summaries and circuit examples in this datasheet are intended to explain typical operation and usage of the product. It is recommended to perform circuit and assembly design considering surrounding conditions upon using products in this datasheet.
7. Technical information described in this datasheet is meant to explain typical operations and applications of products, and it is not intended to guarantee or license intellectual properties or other industrial rights of the third party or Kyocera.
8. Trademarks, logos and brand names used in this datasheet are owned by Kyocera or the corresponding third party.
9. Certain products in this datasheet are subject to the Foreign Exchange and Foreign Trade Control Act of Japan, and require the license from Japanese Government upon exporting the restricted products and technical information under the law. Besides, it is requested not to use products and technical information in the datasheet for the development and/or manufacture of weapons of mass destruction or other conventional weapons, nor to provide them to any third party with the possibility of having such purposes.
10. It is prohibited to reprint and reproduce a part or whole of this datasheet without permission.