

Thyristor Module

K03TF080N040AAA

特徴

Feature

- RoHS 指令準拠
RoHS Compliant

用途

Application

- 一般整流用
For General Use



外形図

Outline Drawing

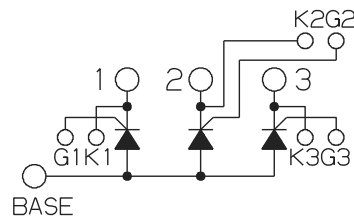
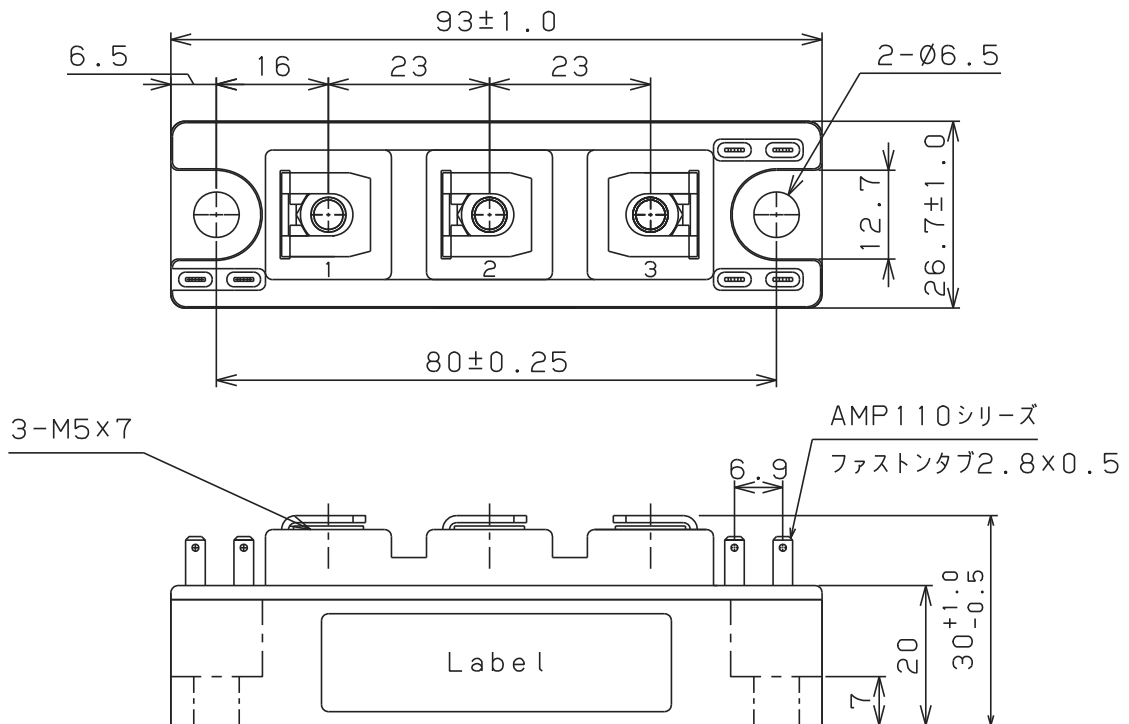

回路構成 Circuit Schema

【単位：mm】

最大定格 Maximum Ratings

項目 Parameter	記号 Symbol	耐圧クラス Grade		単位 Unit
		K03TF080N040AAA		
くり返しピークオフ電圧 Repetitive Peak Off-State Voltage	V _{DRM}	400		V
非くり返しピークオフ電圧 Non Repetitive Peak Off-State Voltage	V _{DSM}	500		V
くり返しピーク逆電圧 Repetitive Peak Reverse Voltage	V _{RRM}	400		V
非くり返しピーク逆電圧 Non Repetitive Peak Reverse Voltage	V _{RSM}	500		V

項目 Parameter	記号 Symbol	条件 Conditions	定格値 Max. Rated Value	単位 Unit		
平均整流電流 Average Rectified Output Current	I _{T(AV)}	商用周波数 180° 通電 Tc=120°C Half Sine Wave	80	A		
実効オン電流 RMS On-State Current	I _T (RMS)		125	A		
サージオン電流 Surge On-State Current	I _{TSM}	50Hz 正弦半波, 1 サイクル, 非くり返し Half Sine Wave, 1Pulse, Non-Repetitive	2300	A		
電流二乗時間積 I Squared t	I ² t	2~10ms	26400	A ² s		
ピークゲート電力損失 Peak Gate Power	P _{GM}		5	W		
平均ゲート電力損失 Average Gate Power	P _{G(AV)}		1	W		
ピークゲート電流 Peak Gate Current	I _{GM}		2	A		
ピークゲート電圧 Peak Gate Voltage	V _{GM}		10	V		
ピークゲート逆電圧 Peak Gate Reverse Voltage	V _{RGM}		5	V		
動作接合温度範囲 Operating Junction Temperature Range	T _{jw}		-40 ~ +150	°C		
保存温度範囲 Storage Temperature Range	T _{stg}		-40 ~ +125	°C		
締付トルク Mounting Torque	ベース部 Base	F	サーマルコンパウンド [®] 塗布 Greased	M6	2.5 ~ 3.5	N・m
	主端子部 Terminal			M5	2.4 ~ 2.8	N・m

1 アーム当りの値 Value Per 1 Arm.

電気的特性 Electrical Characteristics

項目 Parameter	記号 Symbol	条件 Conditions	特性値 Values			単位 Unit
			最小 Min.	標準 Typ.	最大 Max.	
ピークオフ電流 Peak Off-State Current	I _{DM}	T _j = 150°C, V _{DM} = V _{DRM}			20	mA
ピーク逆電流 Peak Reverse Current	I _{RM}	T _j = 150°C, V _{RM} = V _{RRM}			20	mA
ピークオン電圧 Peak On-State Voltage	V _{TM}	T _j = 25°C, I _{TM} = 240A			1.25	V
トリガゲート電流 Gate Current to Trigger	I _{GT}	V _D = 6V, I _T = 1A	T _j = -40°C		200	mA
			T _j = 25°C		100	mA
			T _j = 150°C		40	mA
トリガゲート電圧 Gate Voltage to Trigger	V _{GT}	V _D = 6V, I _T = 1A	T _j = -40°C		4	V
			T _j = 25°C		2.5	V
			T _j = 150°C		1.5	V
非トリガゲート電圧 Gate Non-Trigger Voltage	V _{GD}	T _j = 150°C, V _D = 2/3V _{DRM}	0.2			V
ラッチング電流 Latching Current	I _L	T _j = 25°C		100		mA
保持電流 Holding Current	I _H	T _j = 25°C		50		mA
熱抵抗 Thermal Resistance	R _{th(j-c)}	接合部-ケース間(Tc 測定点:チップ°直下) Junction to Case			0.3	°C/W

質量 --- 約 105g Approximate Weight

1 アーム当りの値 Value Per 1 Arm.

*1 : $V_T \cong V_{(TO)} + I_T \times r_t$ For power-loss calculation only

オン電圧特性
ON-STATE CURRENT VS. VOLTAGE

K03TF080N040AAA Per 1 Arm.

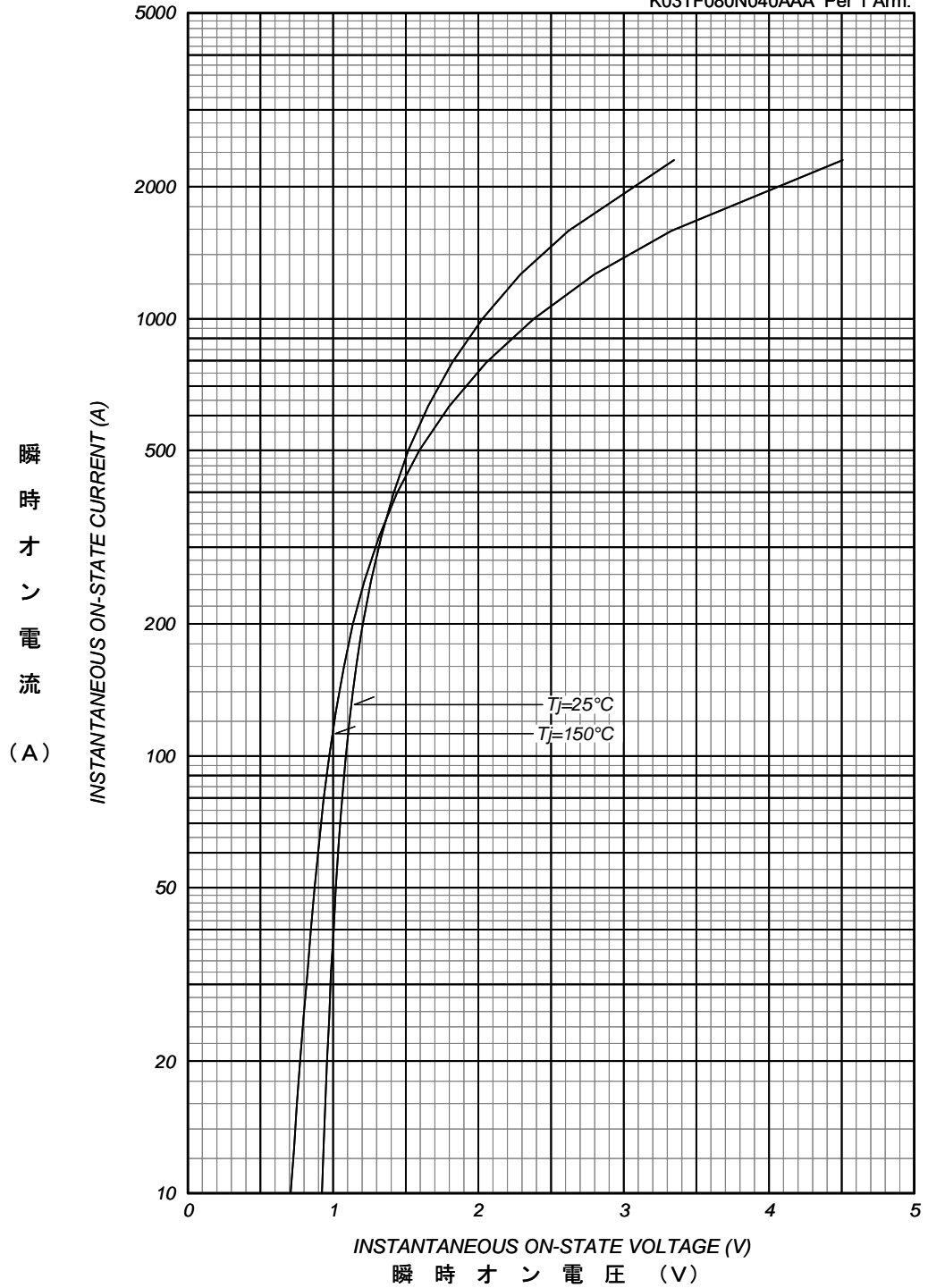

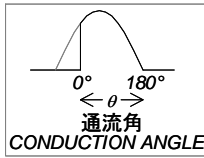

平均オン電力損失特性
AVERAGE ON-STATE POWER DISSIPATION

for SINUSOIDAL CURRENT WAVEFORM

K03TF080N040AAA Per 1 Arm.

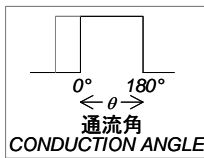
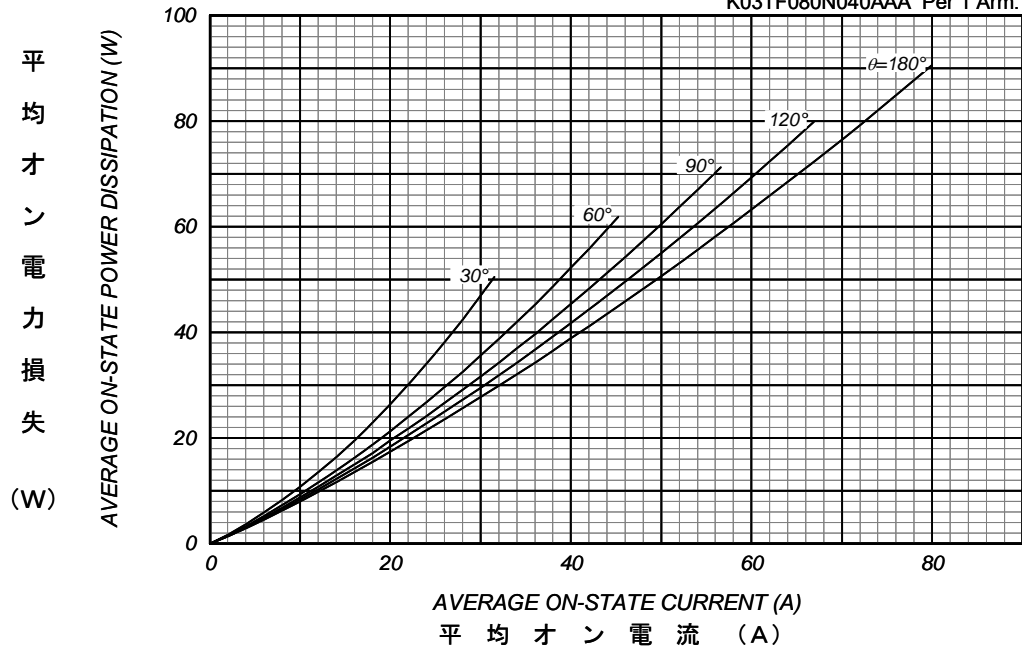

平均オン電力損失特性
AVERAGE ON-STATE POWER DISSIPATION

for RECTANGULAR CURRENT WAVEFORM

K03TF080N040AAA Per 1 Arm.

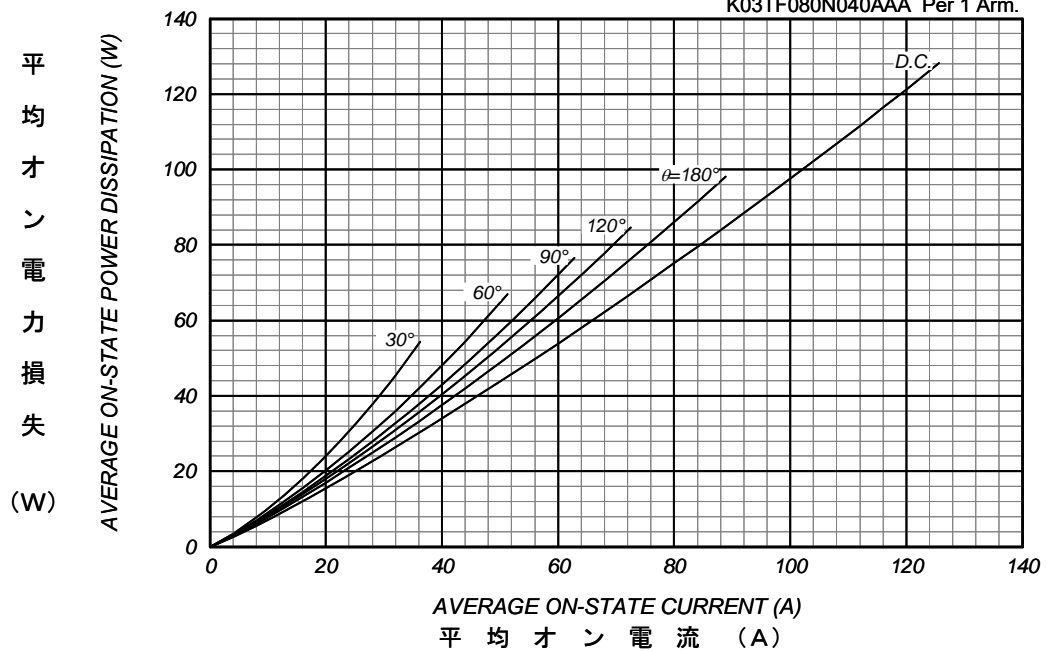

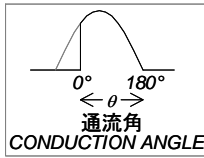

平均オン電流 - ケース温度定格
AVERAGE ON-STATE CURRENT VS. CASE TEMPERATURE

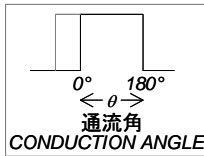
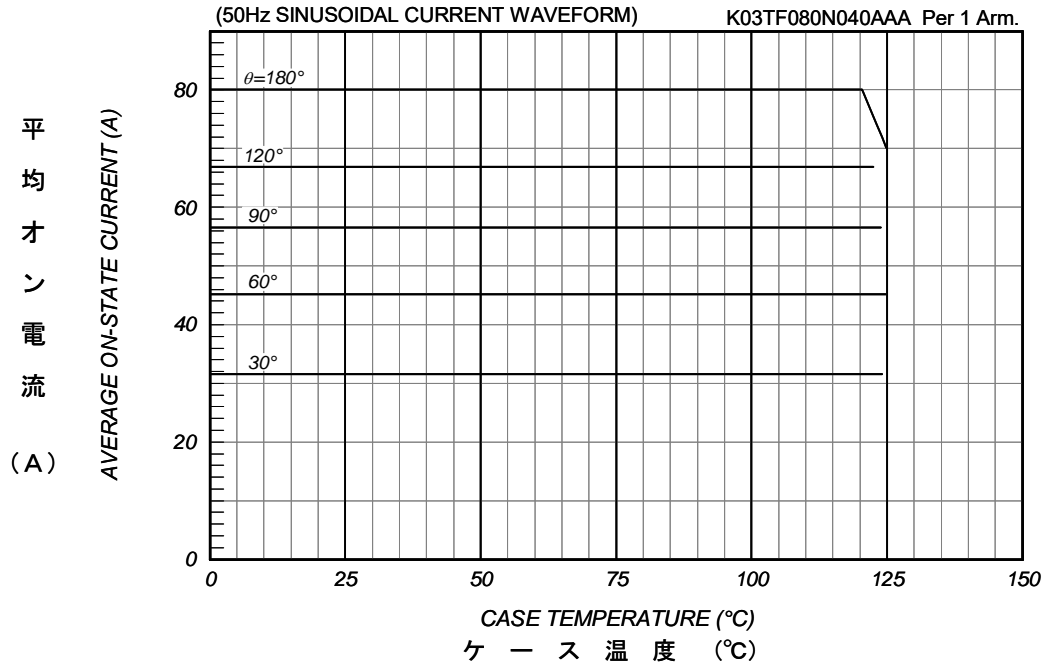

平均オン電流 - ケース温度定格
AVERAGE ON-STATE CURRENT VS. CASE TEMPERATURE

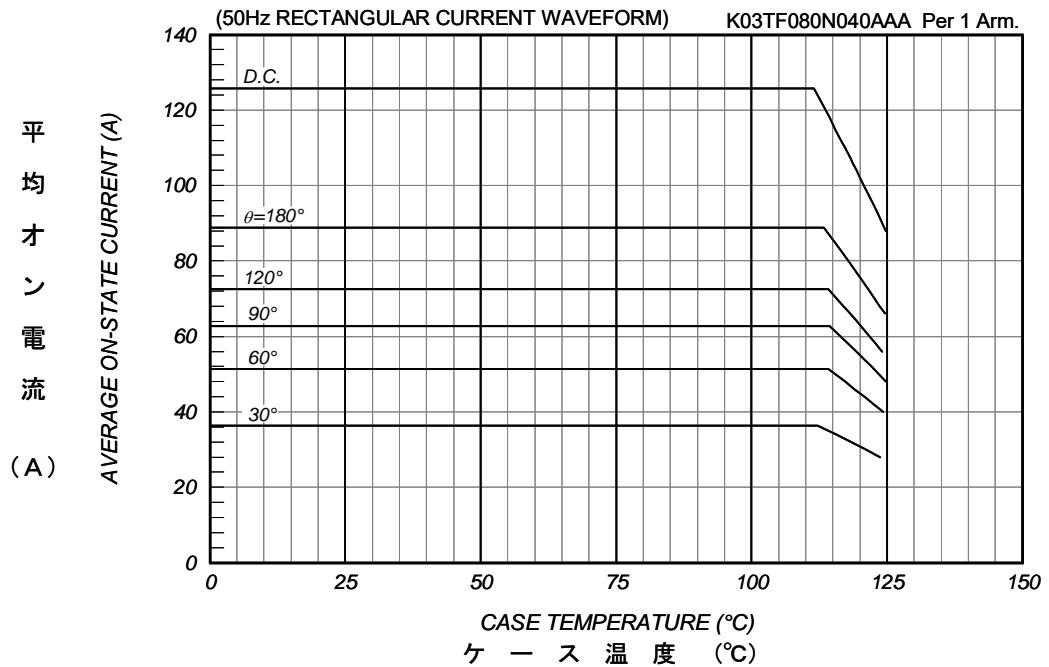

ゲート特性
GATE CHARACTERISTICS

K03TF080N040AAA

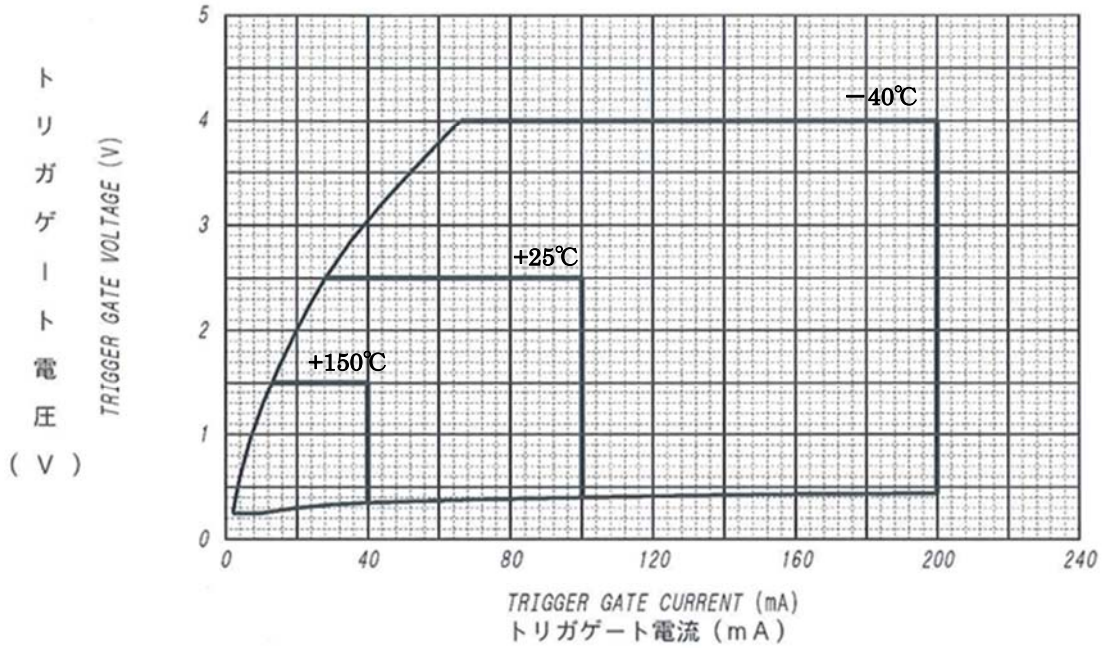

ゲート定格
GATE RATINGS

K03TF080N040AAA

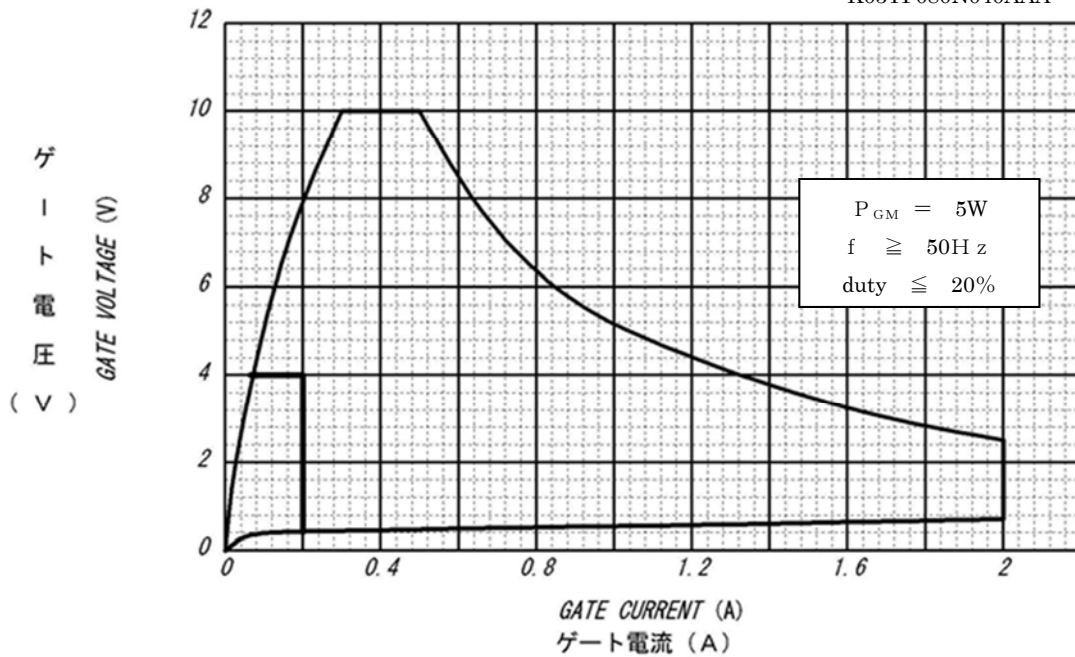

サージオン電流定格
SURGE CURRENT RATINGS

f=50Hz, Half Sine Wave, Non-Repetitive, On Load

K03TF080N040AAA Per 1 Arm.

サ
ー
ジ
オ
ン
電
流
(A)

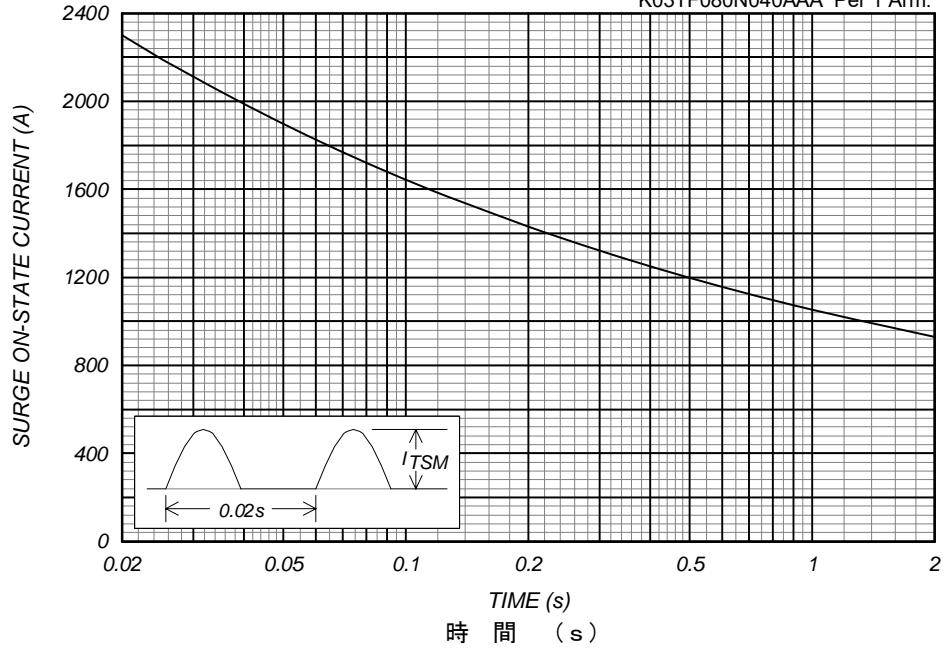

過渡熱抵抗特性
Transient Thermal Impedance

K03TF080N040AAA Per 1 Arm.

過
渡
熱
抵
抗
(°C/W)

