

サイリスタ製品仕様書

THYRISTOR DATA SHEET

仕様書No.QMS7301-302-A0093 (1/8)

I1263PA160

最大定格 Maximum Ratings

項目 Item	記号 Symbol	条件 Condition	定格 Rating	Unit
くり返しピークオフ電圧 Repetitive peak off-state voltage	V_{DRM}		1600	V
非くり返しピークオフ電圧 Non-repetitive peak off-state voltage	V_{DSM}		1600	V
くり返しピーク逆電圧 Repetitive peak reverse voltage	V_{RRM}		1600	V
非くり返しピーク逆電圧 Non-repetitive peak reverse voltage	V_{RSM}		1700	V
平均オン電流 Average on-state current	$I_{O(AV)}$	50Hz Half sine wave, 180° 通電 $T_f=51^{\circ}C$	1000	A
実効オン電流 RMS on-state current	$I_{T(RMS)}$		1571	A
非繰り返しサージオン電流 Non-repetitive Surge on-state current	I_{TSM}	50Hz Half sine wave, 1cycle, $V_R=0V$ $T_j(\text{initial})=125^{\circ}C$	10200	A
電流二乗時間積 I ² t capacity	I^2t	2~10ms	5.20×10^5	A ² s
臨界オン電流上昇率 Critical rate of rise of on-state current	di/dt	$T_j=125^{\circ}C$, $V_D=2/3V_{DRM}$, $I_{TM}=2I_o$ (1KAmax) $di_G/dt=0.5A/\mu s$, $I_G=550mA$, repetitive 50Hz 6s	200	A/ μs
ピークゲート電流 Peak forward gate current	I_{FGM}		7.2	A
ピークゲート逆電圧 Peak reverse gate voltage	V_{RGM}		5	V
平均ゲート電力損失 Average gate power dissipation	$P_{G(AV)}$		4	W
ピークゲート電力損失 Peak gate power dissipation	P_{GM}		30	W
動作接合温度範囲 Operating junction temperature range	T_{jw}		-40~+125	°C
保存温度範囲 Storage temperature range	T_{stg}		-40~+125	°C
圧接力 Mounting force	F	()内は推奨値 () Recommended Value	20 (15)	kN

* 本製品は一般的な電子機器に使用されることを意図しております。極めて高度な信頼性が要求され、その製品の故障や誤動作が直接人命に関わるような機器・装置へのご使用を検討される際は、事前に弊社営業窓口までご相談願います。

* 当仕様書は事前の通知なく改正される事があります。正式採用時には承認図をご請求の上、仕様の確認をして下さい。

Descriptions in this specification are subject to change without announcement.

This product should not be used in any applications requiring extremely higher reliability, where a failure of the product or any consequences of the use of there of can reasonably be expected to result in personal injury or fatal accident, without any prior approval by Kyocera.

サイリスタ製品仕様書

THYRISTOR DATA SHEET

仕様書No.QMS7301-302-A0093 (2/8)

I1263PA160

電気的特性 (指定なき場合は $T_j=25^\circ\text{C}$) Electric Characteristics ($T_j=25^\circ\text{C}$:Unless otherwise specified)

項目 Item	記号 Symbol	条件 Condition	Min.	Typ.	Max.	Unit
ピークオン電圧 Peak on-state voltage	V_{TM}	$T_j=25^\circ\text{C}$, $I_{TM}=3140\text{A}$	-	-	2.75	V
しきい値電圧 Threshold voltage	V_{TO}	$I_{T(AV)} \sim \pi \cdot I_{T(AV)}$, $T_j=125^\circ\text{C}$	-	-	1.28	V
微分抵抗 Slope resistance	r_t	$I_{T(AV)} \sim \pi \cdot I_{T(AV)}$, $T_j=125^\circ\text{C}$	-	-	0.52	$\text{m}\Omega$
ピークオフ電流 Peak off-state current	I_{DRM}	$T_j=125^\circ\text{C}$, $V_D=V_{DRM}$	-	-	100	mA
ピーク逆電流 Peak reverse current	I_{RRM}	$T_j=125^\circ\text{C}$, $V_R=V_{RRM}$	-	-	100	mA
保持電流 Holding current	I_H	$T_j=25^\circ\text{C}$	-	150	-	mA
ラッチング電流 Latching current	I_L	$T_j=25^\circ\text{C}$	-	400	-	mA
トリガゲート電圧 Gate trigger voltage	V_{GT}	$T_j=25^\circ\text{C}$, $V_D=6\text{V}$, $I_T=5\text{A}$	-	-	3	V
トリガゲート電流 Gate trigger current	I_{GT}		-	-	300	mA
非トリガゲート電圧 Gate non-trigger voltage	V_{GD}	$T_j=125^\circ\text{C}$, $V_D=2/3 V_{DRM}$	0.25	-	-	V
臨界オフ電圧上昇率 Critical rate of rise of off-state voltage	dv/dt	$T_j=125^\circ\text{C}$, $V_D=2/3 V_{DRM}$	1000	-	-	$\text{V}/\mu\text{s}$
ターンオフ時間 Turn-off time	t_q	$T_j=125^\circ\text{C}$, $I_{TM}=I_o$ (1KAmax), $V_D=2/3 V_{DRM}$ $dV/dt=20\text{V}/\mu\text{s}$, $V_R=100\text{V}$, $-di/dt=20\text{A}/\mu\text{s}$	-	-	-	μs
ターンオン時間 Turn-on time	t_{gt}	$T_j=25^\circ\text{C}$, $V_D=2/3 V_{DRM}$, $I_{TM}=3I_o$ (1KAmax) $I_G=550\text{mA}$, $di_G/dt=0.5\text{A}/\mu\text{s}$	-	5	-	μs
遅れ時間 Delay Time	t_d		-	3	-	μs
立上り時間 Rise Time	t_r		-	2	-	μs

熱特性 Thermal Characteristics

項目 Item	記号 Symbol	条件 Condition	Min.	Typ.	Max.	Unit
熱抵抗 (接合部-フィン間) Thermal resistance junction to Fin	$R_{th(j-f)}$	Double side cooled, With greased	-	-	0.027	$^\circ\text{C}/\text{W}$

重量 Weight

項目 Item	記号 Symbol	条件 Condition	Min.	Typ.	Max.	Unit
重量 Weight	W_t		-	140	-	g

オン電圧特性
ON-STATE CURRENT VS. VOLTAGE

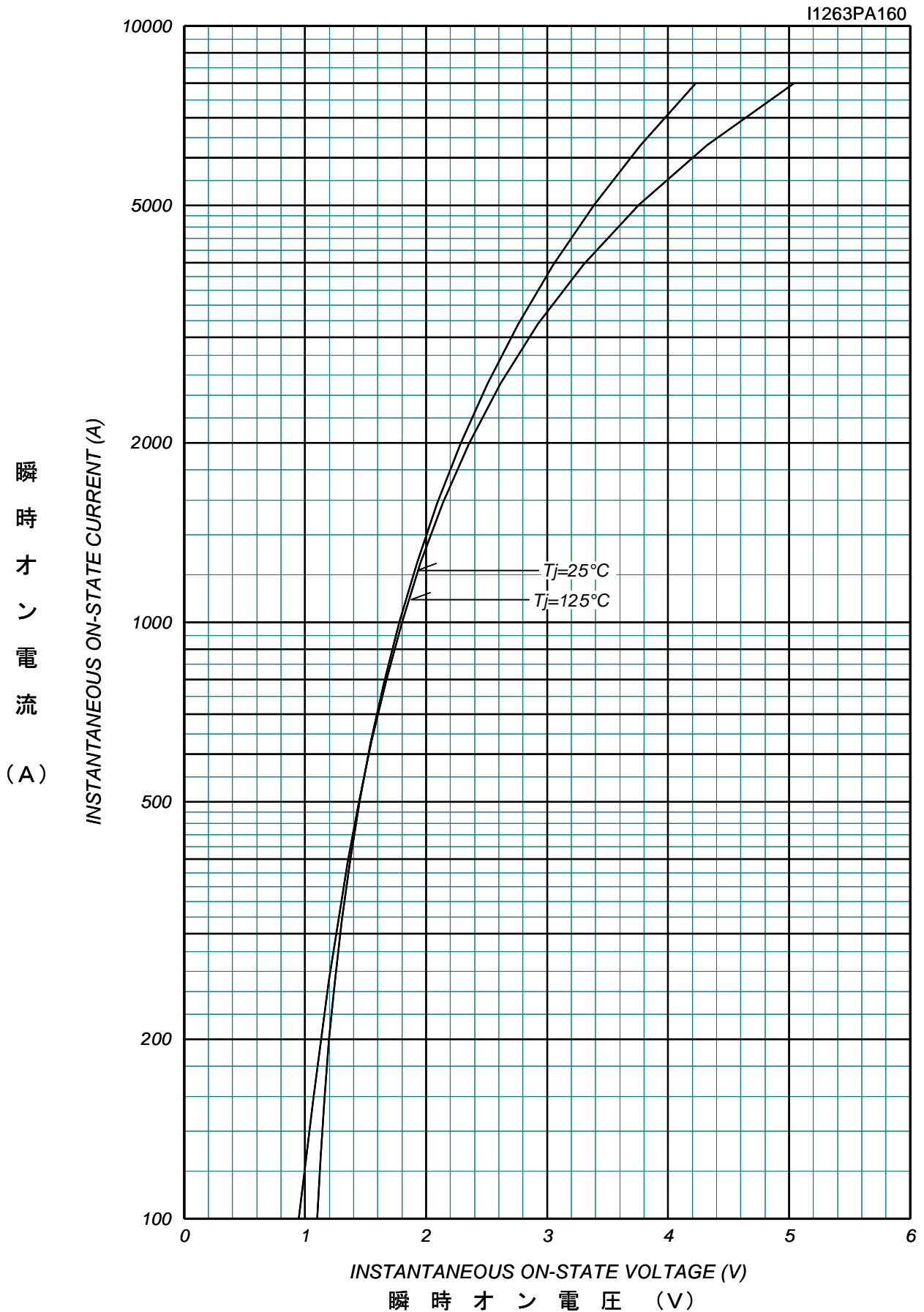

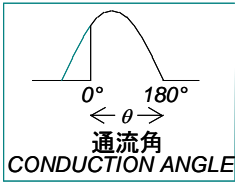

平均オン電力損失特性 AVERAGE ON-STATE POWER DISSIPATION

for SINUSOIDAL CURRENT WAVEFORM

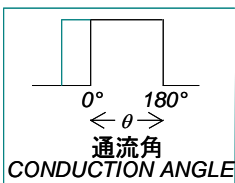
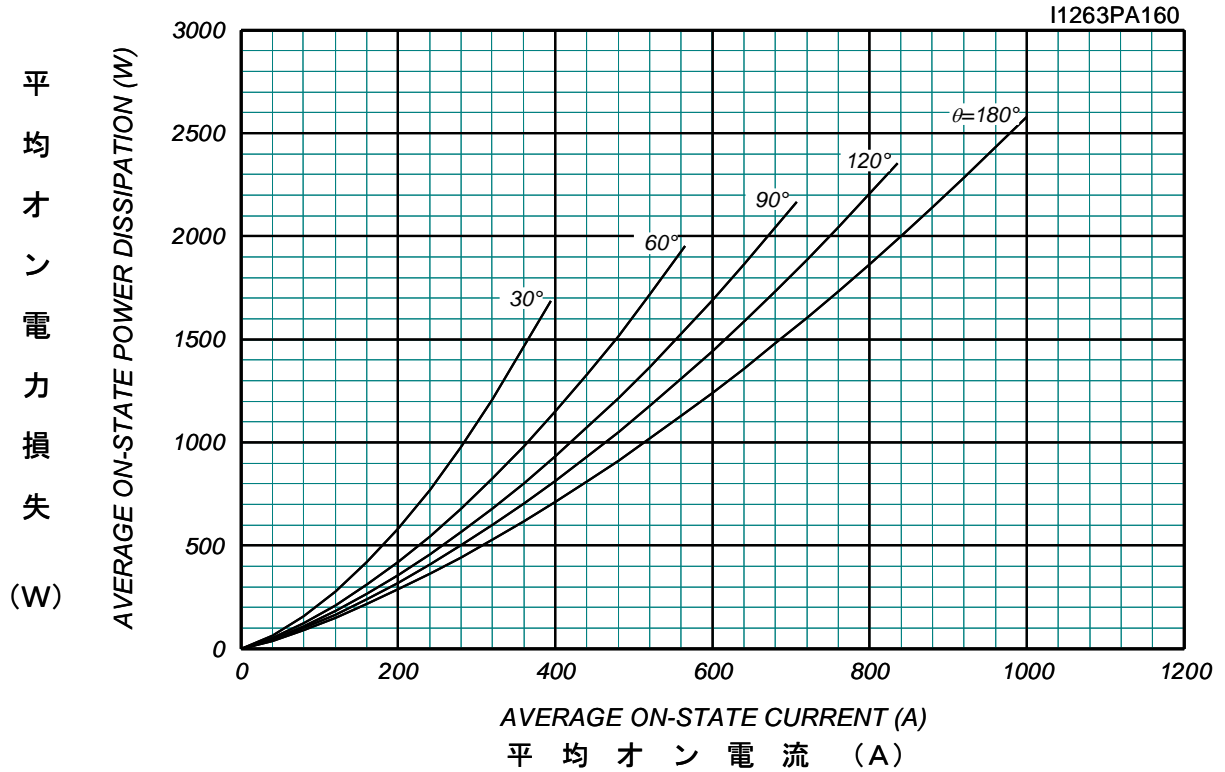

平均オン電力損失特性 AVERAGE ON-STATE POWER DISSIPATION

for RECTANGULAR CURRENT WAVEFORM

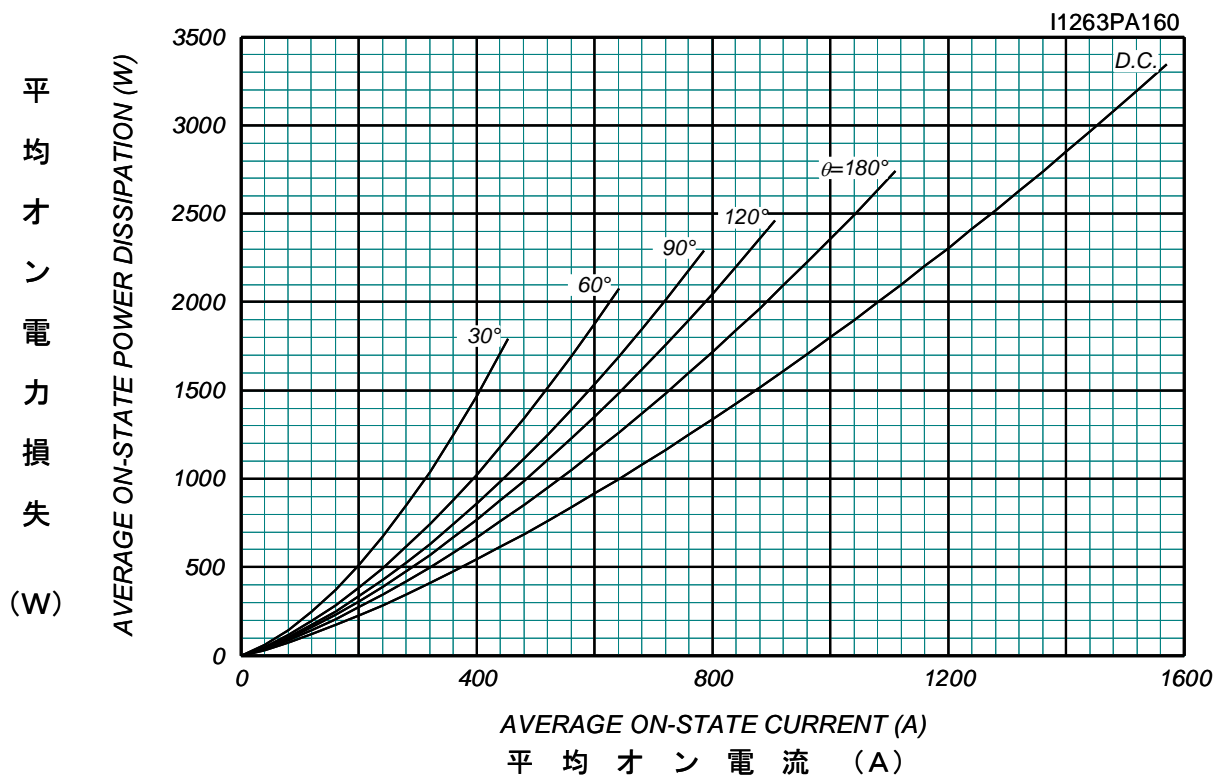

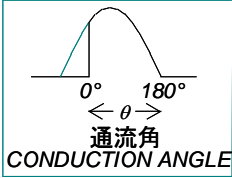

平均オン電流 - フィン温度定格
AVERAGE ON-STATE CURRENT VS. FIN TEMPERATURE

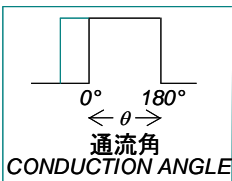
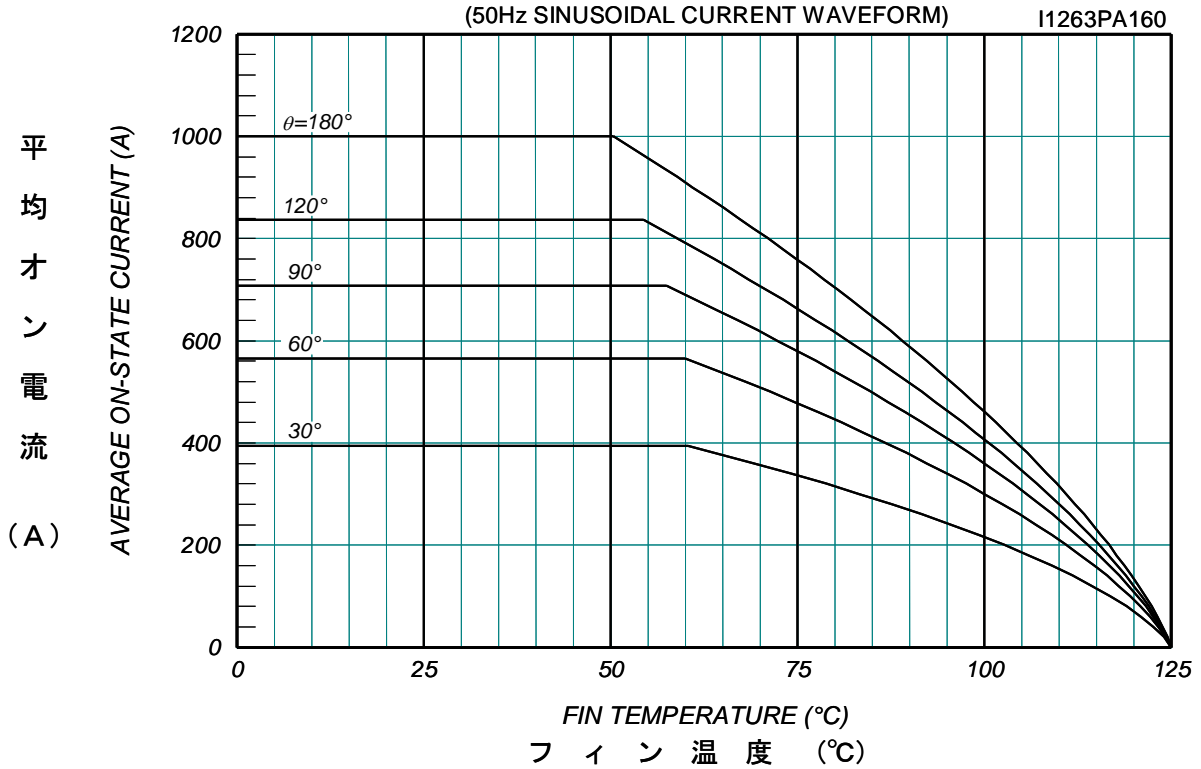

平均オン電流 - フィン温度定格
AVERAGE ON-STATE CURRENT VS. FIN TEMPERATURE

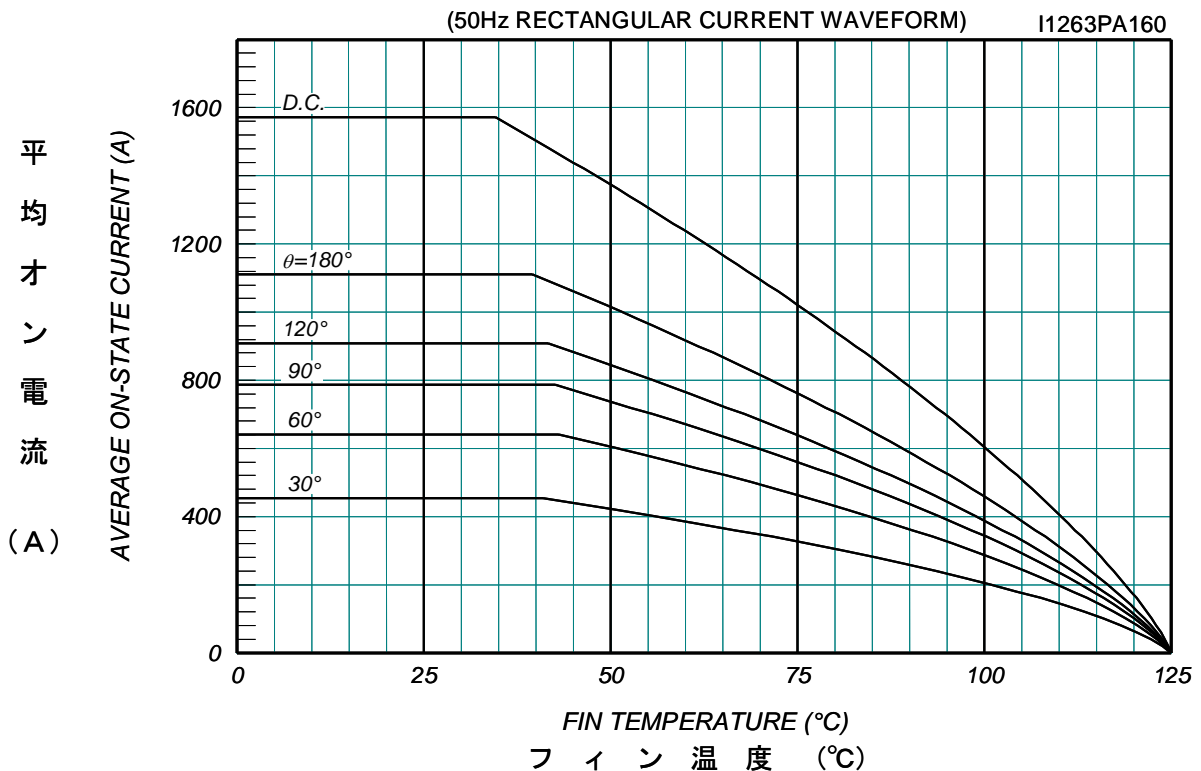

ゲート特性 GATE CHARACTERISTICS

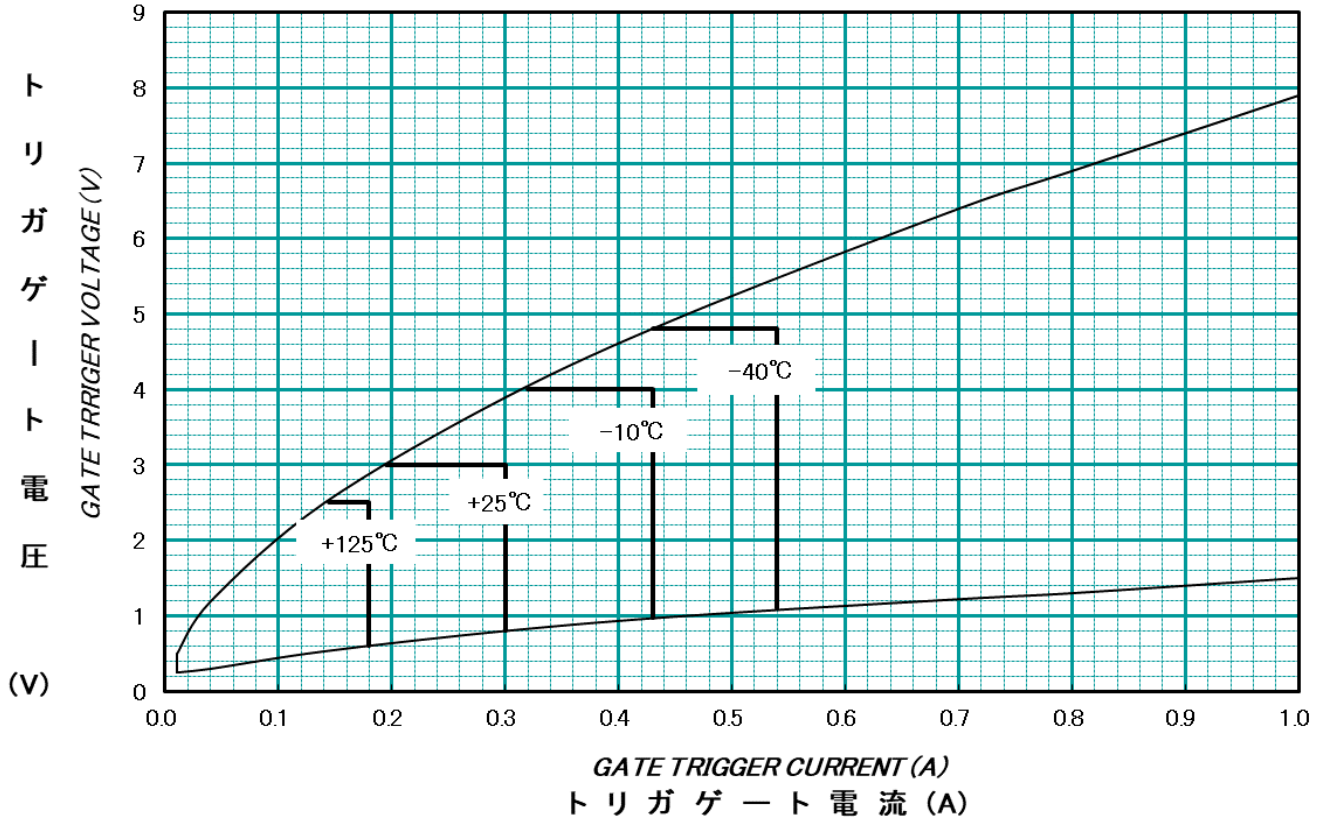

ゲート定格 GATE RATINGS

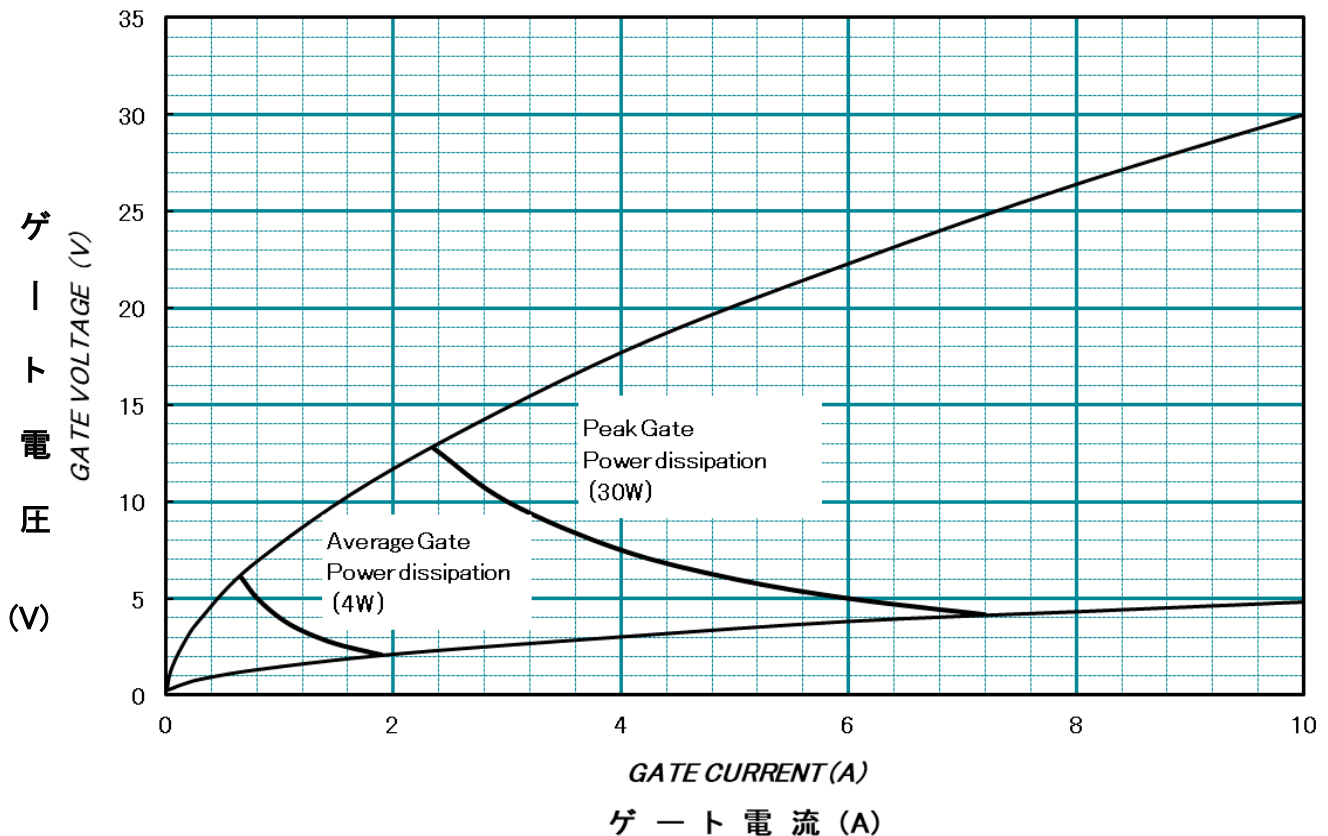

サージオン電流定格

SURGE CURRENT RATINGS

f=50Hz, Half Sine Wave, Non-Repetitive, On Load

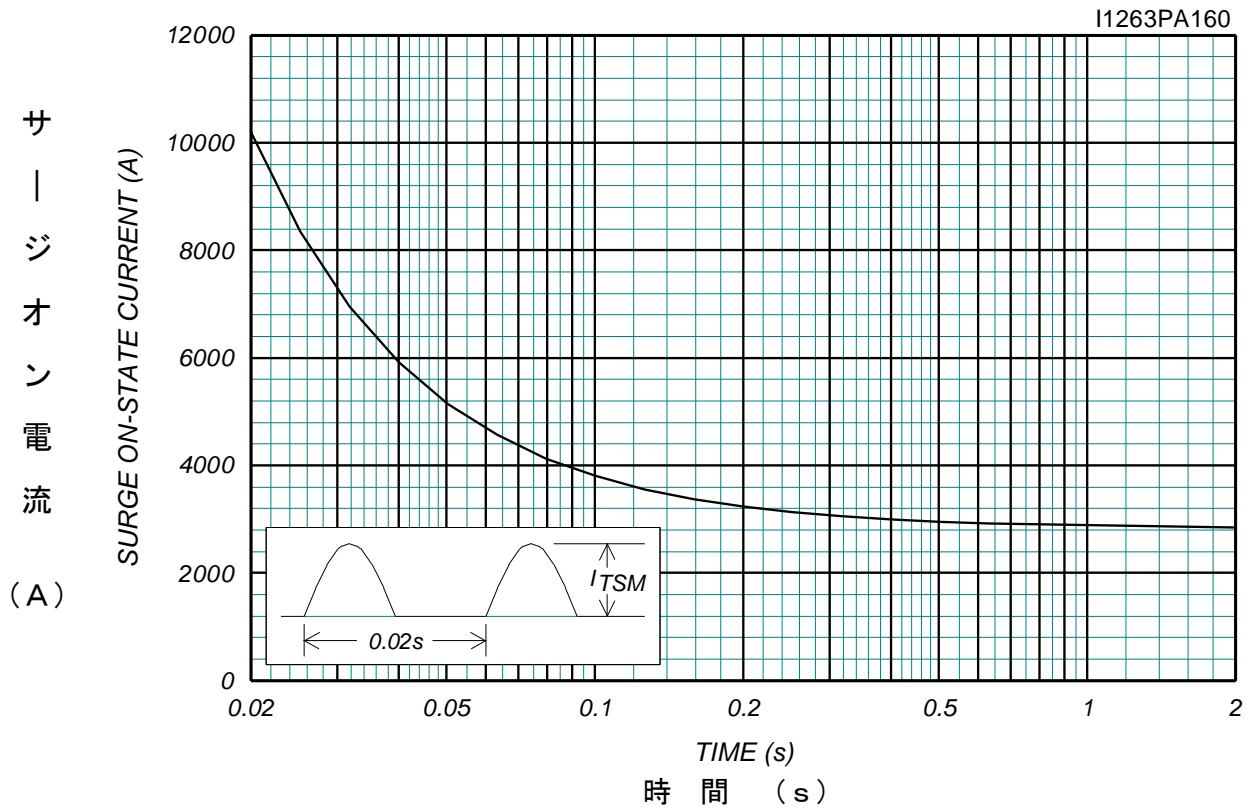

過渡熱抵抗特性

Transient Thermal Impedance

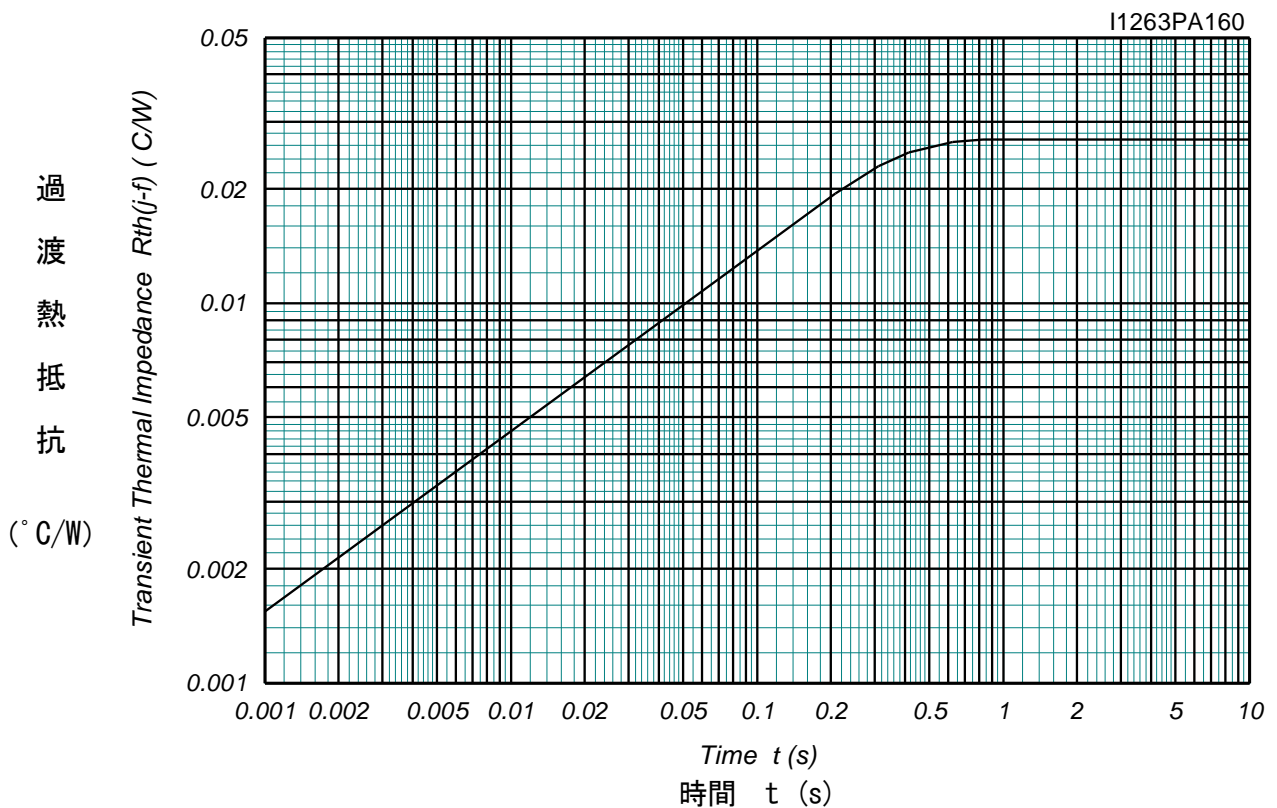

逆回復特性
 Reverse Recovery Characteristics

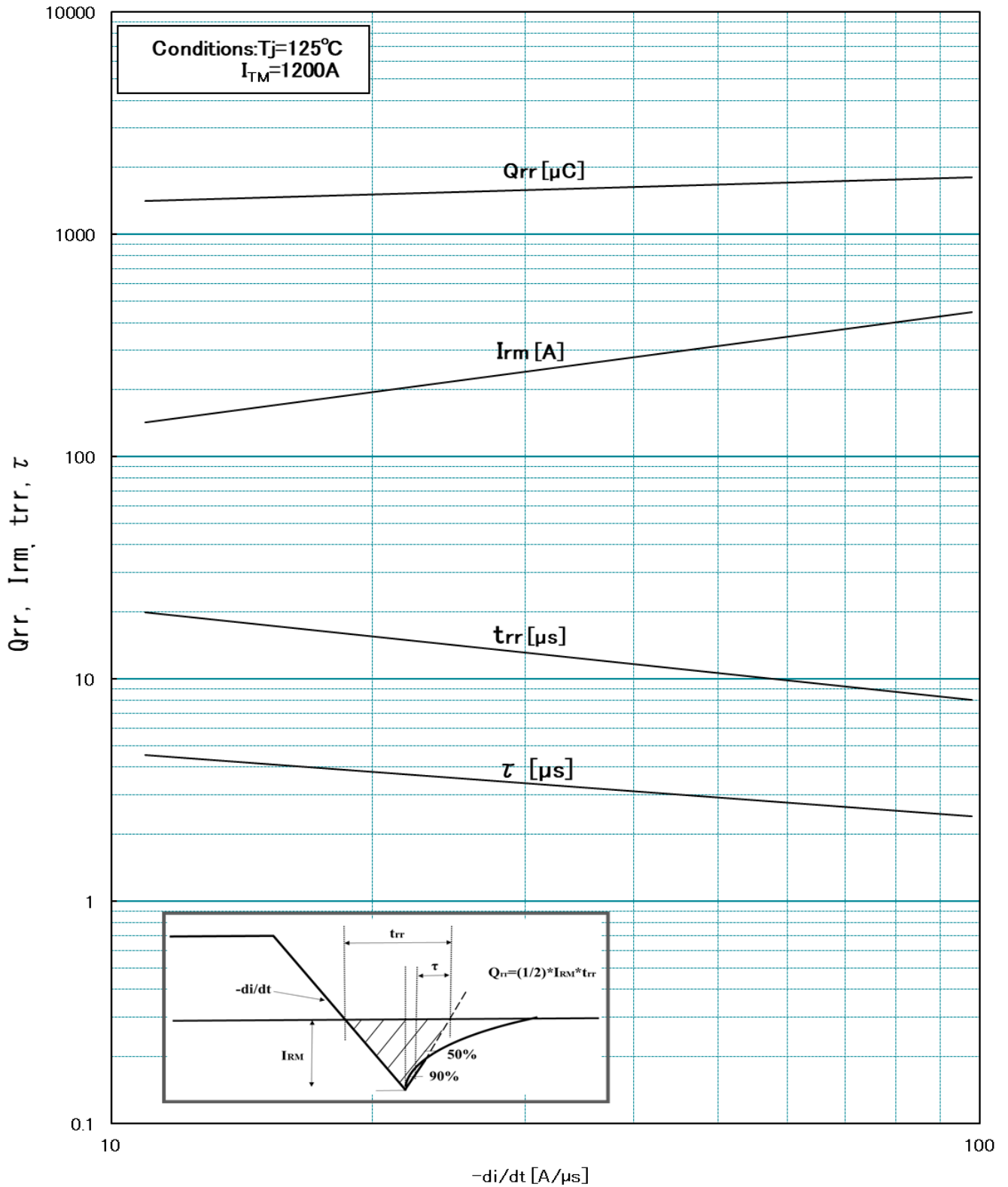

1

2

3

4

A

A

B

B

C

C

D

D



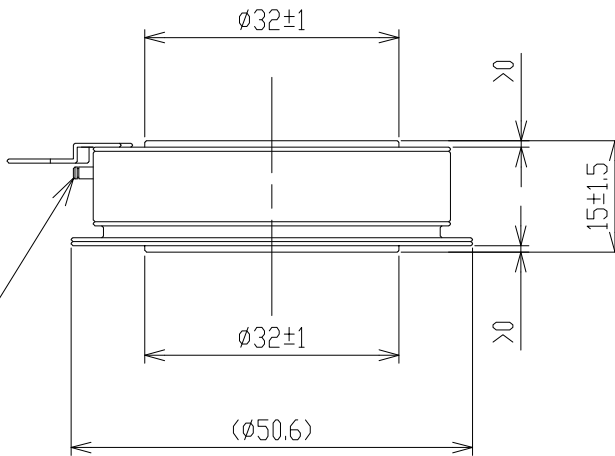
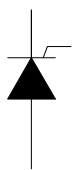
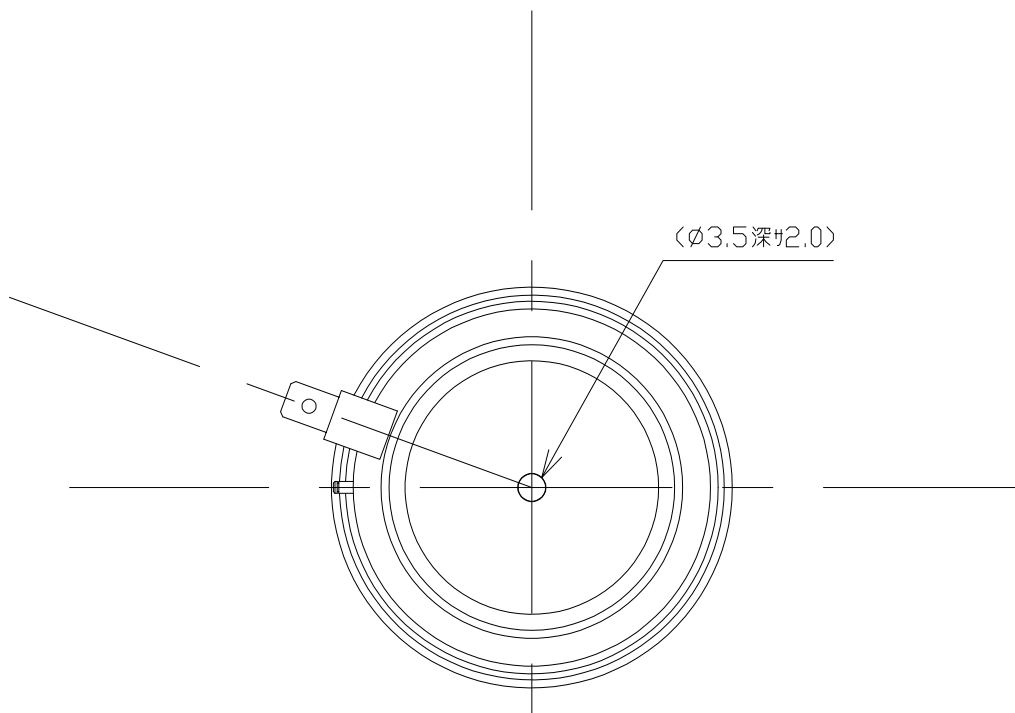

E

E

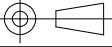

AMP用ケーブル60598-1に対応

 SCALE 1:1
 UNIT: mm

							Q A	APPD.承認	朝倉
							作成部署	APPD.承認	北西
						CHKD.検図		松山	
						DWN.作図		武田	
						DATE年月日		23.04.21	
REV.変更記号	REVISION改訂	DATE年月日	REV.D.担当	APPD.承認	QA APPD. QA承認	SDRT種類	外形寸法図	DRG.No.:図番	



TITLE: 型名
I1263PA160

DRG.No.: 図番
QMS7308-23-70001-21

REV. 変更記号

1

2

3

4

F

F