

Specifications

Drawing No.	UKY1C-H2-25AAA-00[37] 1/10
Issued Date.	2025/06/30

TO:

Note:

In case of specification change, KYOCERA Part Number also will be changed.

Product Type	Quartz Crystal
Series	CX3225SA
Frequency	8000 kHz
Customer Part Number	-
Customer Specification Number	-
KYOCERA Part Number	CX3225SA08000D0GTWL1
Remarks	Pb-Free, RoHS Compliant, MSL 1, AEC-Q200 Compliant

Customer Approval

Approval Signature	Approved Date	
	Department	
	Person in charge	

Seller

KYOCERA Corporation
Corporate Electronic Components Group
Electronic Components Sales Division

6 Takeda Tobadono-cho, Fushimi-ku, Kyoto
612-8501 Japan
TEL. No. 075-604-3500
FAX. No. 075-604-3501

Manufacturer

RF Devices Division
Corporate Electronic Components Group
Crystal Components Division

Design Department	Quality Assurance	Approved by	Checked by	Checked by	Issued by
KYOCERA Corporation Crystal Components Application Engineering Section 2 Electronic Devices Division Corporate Electronic Components Group	-	-	-	-	-

Revision History

Rev.No.	Description of revision	Date	Approved by	Checked by	Issued by
00	First Edition	2025/06/30	-	-	-

1 APPLICATION

This specification sheet is applied to quartz crystal "CX3225SA08000D0GTWL1"

2 KYOCERA PART NUMBER

CX3225SA08000D0GTWL1

3 RATINGS

Items	Symb.	Rating	Unit	Remarks
Operating Temperature Range	Topr	-40 to +150	°C	
Storage Temperature Range	Tstg	-40 to +150	°C	

4 CHARACTERISTICS

ELECTRICAL CHARACTERISTICS

Items	Electrical Specification					Test Condition	Remarks
	Symb.	Min.	Typ.	Max.	Unit		
Mode of Vibration		Fundamental					
Nominal Frequency	F0		8		MHz		
Nominal Temperature	T _{NOM}		+25		°C		
Load Capacitance	CL	8			pF		
Frequency Tolerance	df/F	-15		+15	PPM	+25±3°C	
Frequency Temperature Characteristics	df/F	-200		+200		-40 to +150 °C	Based on an oscillation frequency at +25 °C
Frequency Aging Rate		-2.0		+2.0		1 st year	+25±3°C
Equivalent Series Resistance	ESR			500	Ω		
Drive Level	Pd	0.01		200	μW		
Insulation Resistance	IR	500			MΩ	100V(DC)	

5 Measurement Condition

(1) Frequency measurement

Measuring instrument : IEC PI-Network Test Fixture
 Load Capacitance : 8pF
 Drive Level : 10μW

(2) Equivalent series resistance (ESR) measurement

Measuring instrument : IEC PI-Network Test Fixture
 Load Capacitance : Series
 Drive Level : 10μW

6 APPEARANCES, DIMENSIONS

(1) OUTLINE DIMENSION (not to scale)

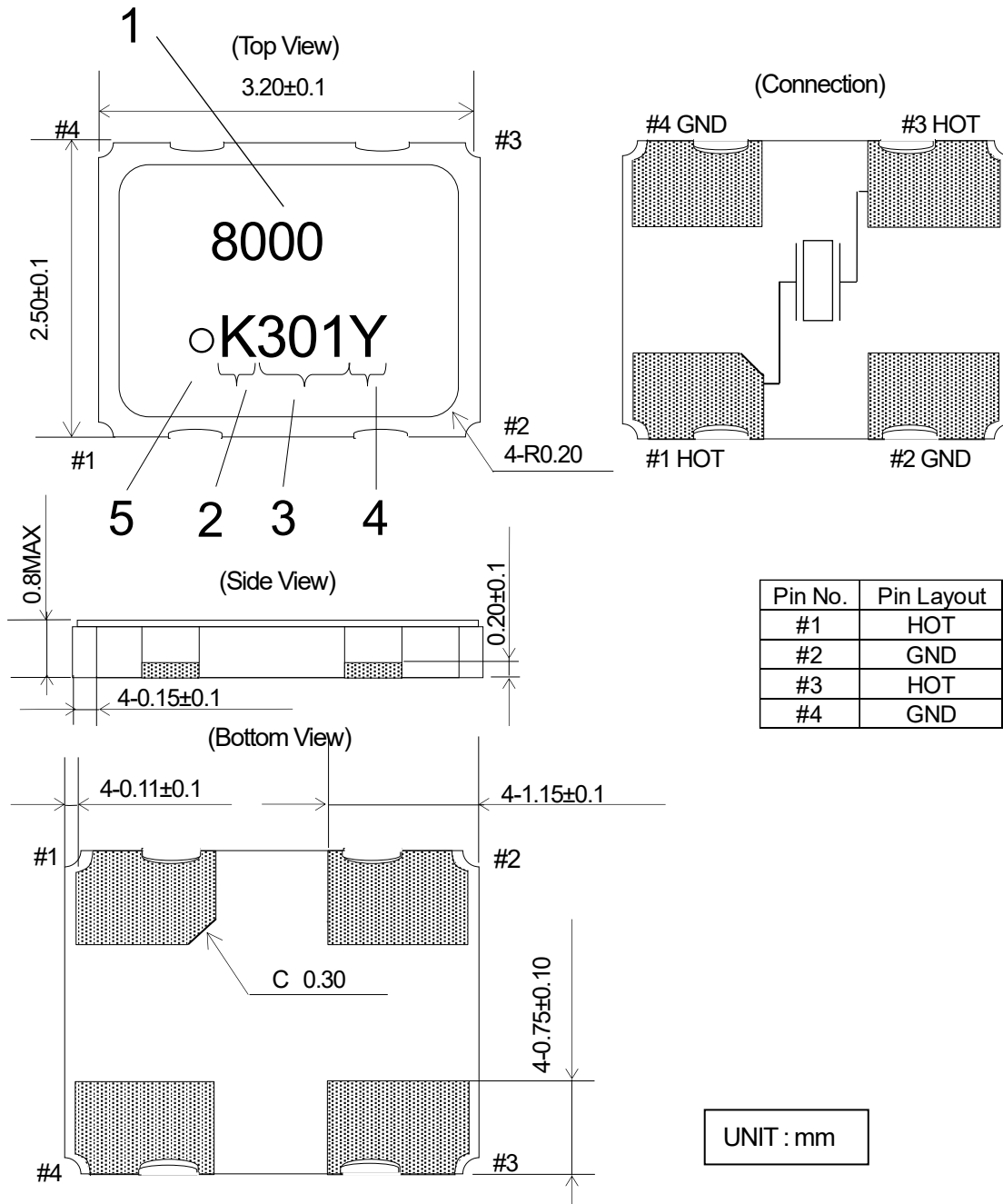

(2) MARKING

- | | |
|---------------------------|---|
| 1. Nominal Frequency | First 5 digits of the frequency is indicated. |
| 2. Identification | [K] mark is surely 1 pin direction. |
| 3. Date Code | Last 1 digit of YEAR and WEEK (Ex) 2022, Jan, 01 -> 201 |
| 4. Manufacturing Location | Y...Japan (Yamagata) |
| 5. No.1 pin is expressed. | |

Note: The font of marking is for reference only.

7 RECOMMENDED LAND PATTERN (not to scale)

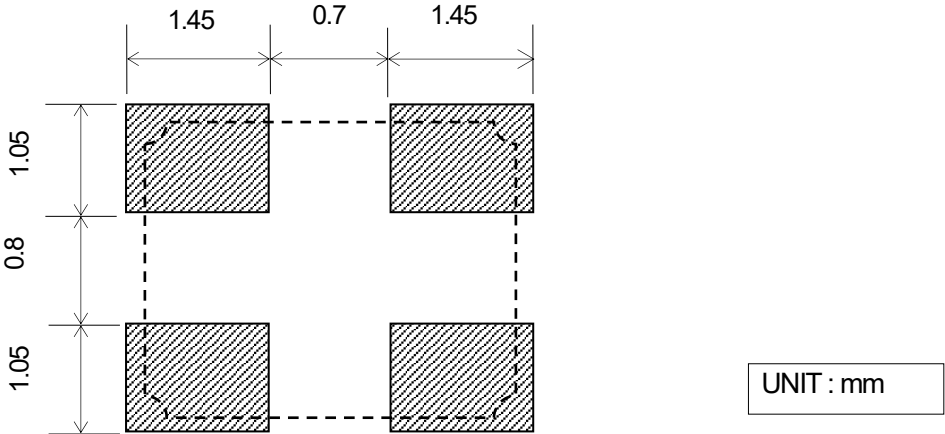

8 TAPING & REEL

(1) Dimensions

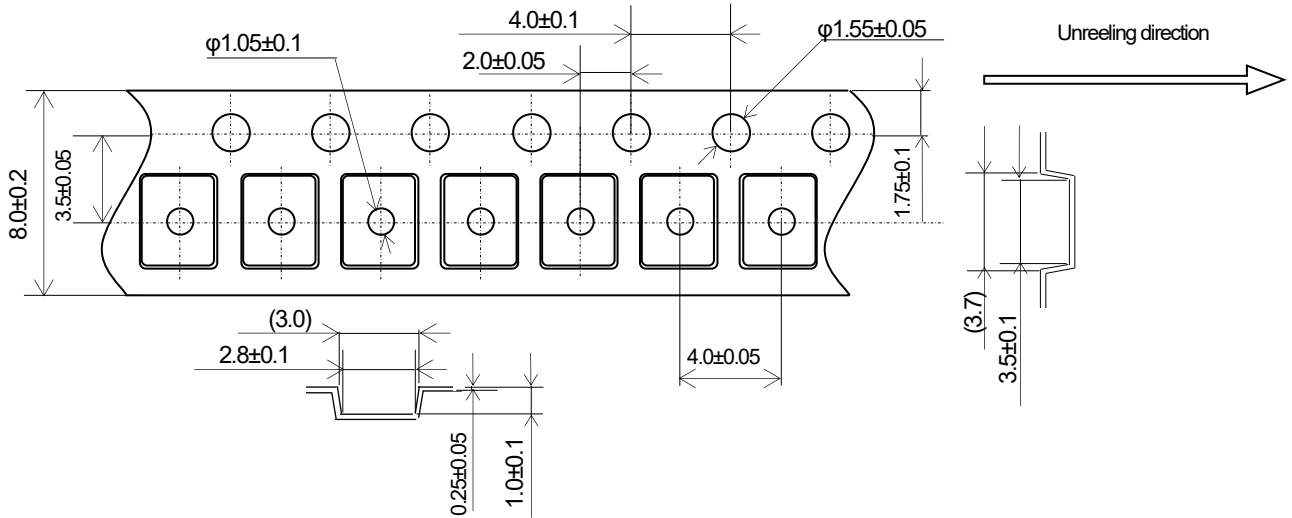

(2) Leader and trailer tape

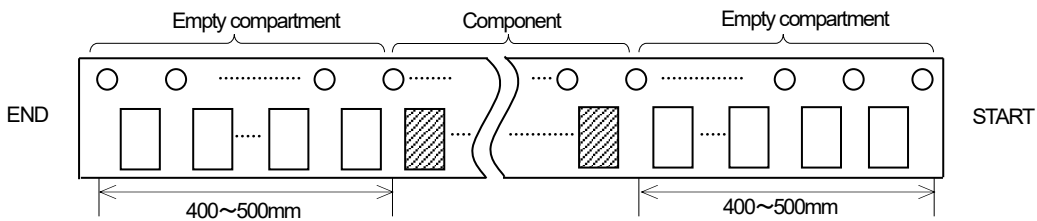

(3) Direction (The direction shall be seen from the top cover tape side)

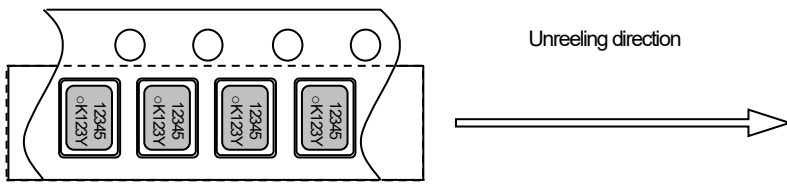

(4) Specification

1. Material of the carrier tape is either polystyrene or A-PET (ESD).
2. Material of the cover tape is PET/PE (ESD).
3. The seal tape shall not cover the sprocket holes and not protrude from the carrier tape.
4. Tensile strength of carrier tape: 10N or more.
5. The R of the corner of each cavity is 0.2R max.
6. The alignment between centers of the cavity and sprocket hole shall be 0.05mm or less.
7. The orientation shall be checked from the top cover tape side as shown in 8-(3).
8. Peeling force of cover tape: 0.1 to 1.0N.
9. The component will fall out naturally when cover tape is removed and set upside down.

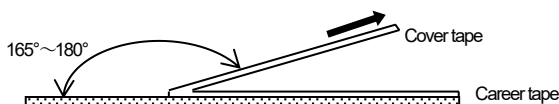

(5) Reel Specification

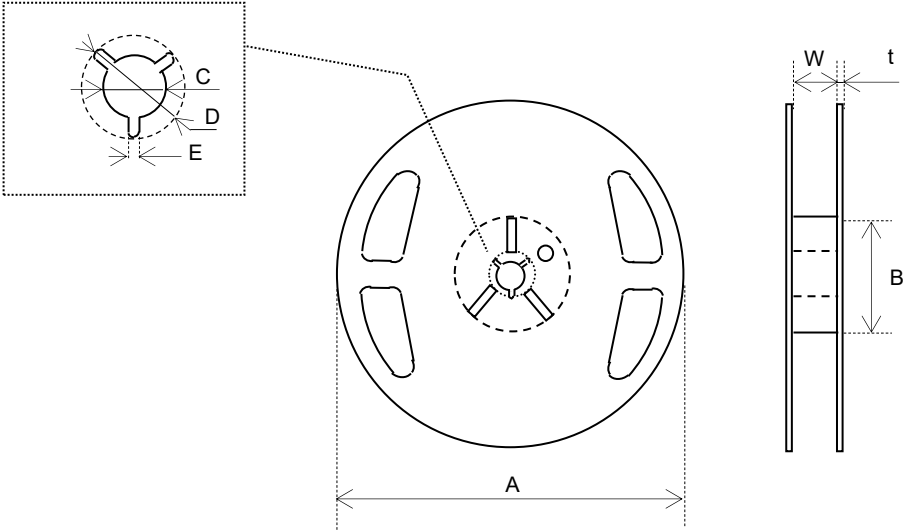

φ180 Reel (3,000pcs max.)

Symbol	A	B	C	D
Dimension	φ180 +0/-3	φ60 +1/-0	φ13±0.2	φ21±0.8
Symbol	E	W	t	
Dimension	2.0±0.5	9±1	2.0±0.5	

(Unit : mm)

φ330 Reel (15,000pcs max.)

Symbol	A	B	C	D
Dimension	φ330±2.0	φ100±1.0	φ13±0.2	φ21±0.8
Symbol	E	W	t	
Dimension	2.0±0.5	9.5±0.5	2.2±0.1	

(Unit : mm)

9 ENVIRONMENTAL AND MECHANICAL CHARACTERISTICS :

(The solder used for the test is Pb-Free Sn-3Ag-0.5Cu.)

After following test, frequency shall not change more than $\pm 10 \times 10^{-6}$ and Cl, $\pm 20\%$ or 5Ω .

No	Stress	Reference	Additional Requirements
9.1	High Temperature Exposure (Storage)	MIL-STD-202 Method 108	1000 hrs. at rated operating temperature (e.g. 85°C part can be stored for 1000 hrs at 85°C. Same applies for 125°C). Unpowered. Measurement at 24±4 hours after test conclusion.
9.2	Temperature Cycling	JESD22 Method JA-104	1000 cycles (-40°C to 125°C) Note: If 85°C part the 1000 cycles will be at that temperature rating. Measurement at 24±4 hours after test conclusion. 30min maximum dwell time at each temperature extreme. 1 min. maximum transition time.
9.3	Biased Humidity	MIL-STD- 202 Method 103	1000 hours 85°C/85%RH. Rated VDD applied with 1 MW and inverter in parallel, 2X crystal CL capacitors between each crystal leg and GND. Measurement at 24±4 hours after test conclusion.
9.4	Operational Life	MIL-STD- 202 Method 108	Note: 1000 hrs @ 125°C. If 85°C part will be tested at that temperature. Rated VDD applied with 1 MW and inverter in parallel, 2X crystal CL capacitors between each crystal leg and GND. Measurement at 24±4 hours after test conclusion.
9.5	Terminal Strength (Leaded)	MIL-STD- 202 Method 211	Test leaded device lead integrity only. Conditions: A (227 g), C (227 g).
9.6	Resistance to Solvents	MIL-STD- 202 Method 215	Note: Also aqueous wash chemical - OKEM clean or equivalent. Do not use banned solvents.
9.7	Mechanical Shock	MIL-STD-202 Method 213	Figure 1 of Method 213. Condition C
9.8	Vibration	MIL-STD-202 Method 204	5g's for 20 minutes 12 cycles each of 3 orientations. Note: Use 8"X5" PCB .031" thick with 7 secure points on one 8" side and 2 secure points on corners of opposite sides. Parts mounted within 2" from any secure point. Test from 10-2000 Hz.
9.9	Resistance to Soldering Heat	MIL-STD-202 Method 210	Condition B No pre-heat of samples. Note: Single Wave solder - Procedure 1 with solder within 1.5 mm of device body for Leaded. Procedure 1 except 230°C and immerse only to level to cover terminals for SMD.
9.10	Solder ability	J-STD-002	For both Leaded & SMD. Electrical Test not required. Magnification 50 X. Conditions: Leaded: Method A @ 235°C, category 3. SMD: a) Method B, 4 hrs @ 155°C dry heat @ 235°C b) Method B @ 215°C category 3. c) Method D category 3 @ 260°C.
9.11	Flammability	UL-94	V-0 or V-1 Acceptable
9.12	Board Flex	AEC Q200-005	60 sec minimum holding time.
9.13	Terminal Strength (SMD)	AEC Q200-006	-

10 SOLDERING CONDITION

- (1) Material of solder
Kind ... lead free solder paste
Melting point ... $+220\pm 5^{\circ}\text{C}$
- (2) Reflow temp.profile

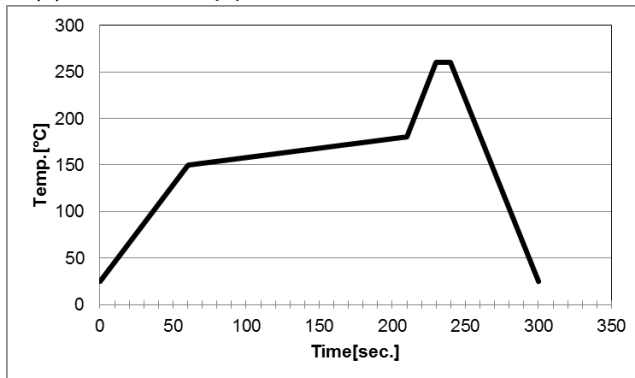

	Temp [°C]	Time[sec]
Preheating	+150 to +180	150 (typ.)
Peak	+260±5	10 (max.)
Total	—	300 (max.)

- (3) Hand Soldering
+350°C 3 sec max.
- (4) Reflow Times
2 times

11 CAUTIONS FOR USE

- (1) Soldering upon mounting
There is a possibility to influence product characteristics when solder paste or conductive glue comes in contact with product lid or surface.
- (2) When using mounting machine
Please minimize the shock when using mounting machine to avoid any excess stress to the product.
- (3) Conformity of a circuit
We strongly recommend to make sure that Negative resistance (Gain) of IC is designed to be 10 times the ESR (Equivalent Series Resistance) of crystal unit.

12 STORAGE CONDITIONS

Please store product in below conditions, and use within 6 months.
Temperature +18 to +30°C, and Humidity of 20 to 70 % in the packaging condition.

13 MANUFACTURING LOCATION

KYOCERA Corporation Yamagata Higashine Plant / Japan (Yamagata)

14 Quality Assurance

To be guaranteed by KYOCERA Corporation Yamagata Higashine Plant Quality Assurance Division

15 Quality guarantee

In case when KYOCERA Corporation rooted failure occurred within 1 year after its delivery, substitute product will be arranged based on discussion. Quality guarantee of product after 1 year of its delivery is waived.

16 Others

In case of any questions or opinions regarding the Specification, please have it in written manner within 45 days after issued date.