

Specifications

Drawing No.	UKY1C-H2-25AAA-00[37] 1/10
Issued Date.	2025/06/27

TO:

Note:

In case of specification change, KYOCERA Part Number also will be changed.

Product Type	Quartz Crystal
Series	CX3225GA
Frequency	8000 kHz
Customer Part Number	-
Customer Specification Number	-
KYOCERA Part Number	CX3225GA08000P0PSVTT
Remarks	Pb-Free, RoHS Compliant, MSL 1, AEC-Q200 Compliant

Customer Approval

Approval Signature	Approved Date	
	Department	
	Person in charge	

Seller

KYOCERA Corporation
 Corporate Electronic Components Group
 Electronic Components Sales Division

6 Takeda Tobadono-cho, Fushimi-ku, Kyoto
 612-8501 Japan
 TEL. No. 075-604-3500
 FAX. No. 075-604-3501

Manufacturer

RF Devices Division
 Corporate Electronic Components Group
 Crystal Components Division

Design Department	Quality Assurance	Approved by	Checked by	Checked by	Issued by
KYOCERA Corporation Crystal Components Application Engineering Section 2 Electronic Devices Division Corporate Electronic Components Group	-	-	-	-	-

Revision History

Rev.No.	Description of revision	Date	Approved by	Checked by	Issued by
00	First Edition	2025/06/27	-	-	-

1 APPLICATION

This specification sheet is applied to quartz crystal "CX3225GA08000P0PSVTT"

2 KYOCERA PART NUMBER

CX3225GA08000P0PSVTT

3 RATINGS

Items	Symb.	Rating	Unit	Remarks
Operating Temperature Range	Topr	-40 to +125	°C	
Storage Temperature Range	Tstg	-40 to +150	°C	

4 CHARACTERISTICS

ELECTRICAL CHARACTERISTICS

Items	Electrical Specification					Test Condition	Remarks
	Symb.	Min.	Typ.	Max.	Unit		
Mode of Vibration		Fundamental					
Nominal Frequency	F0		8		MHz		
Nominal Temperature	T _{NOM}		+25		°C		
Load Capacitance	CL	18			pF		
Frequency Tolerance	df/F	-50		+50	PPM	+25±3°C	
Frequency Temperature Characteristics	df/F	-150		+150		-40 to +125 °C	Based on an oscillation frequency at +25 °C
Frequency Aging Rate		-5.0		+5.0		1 st year	+25±3°C
Equivalent Series Resistance	ESR			500	Ω		
Drive Level	Pd	0.01		200	μW		
Insulation Resistance	IR	500			MΩ	100V(DC)	

5 Measurement Condition

(1) Frequency measurement

Measuring instrument : IEC PI-Network Test Fixture

Load Capacitance : 18pF

Drive Level : 10μW

(2) Equivalent series resistance (ESR) measurement

Measuring instrument : IEC PI-Network Test Fixture

Load Capacitance : Series

Drive Level : 10μW

6 APPEARANCES, DIMENSIONS

(1) OUTLINE DIMENSION (not to scale)

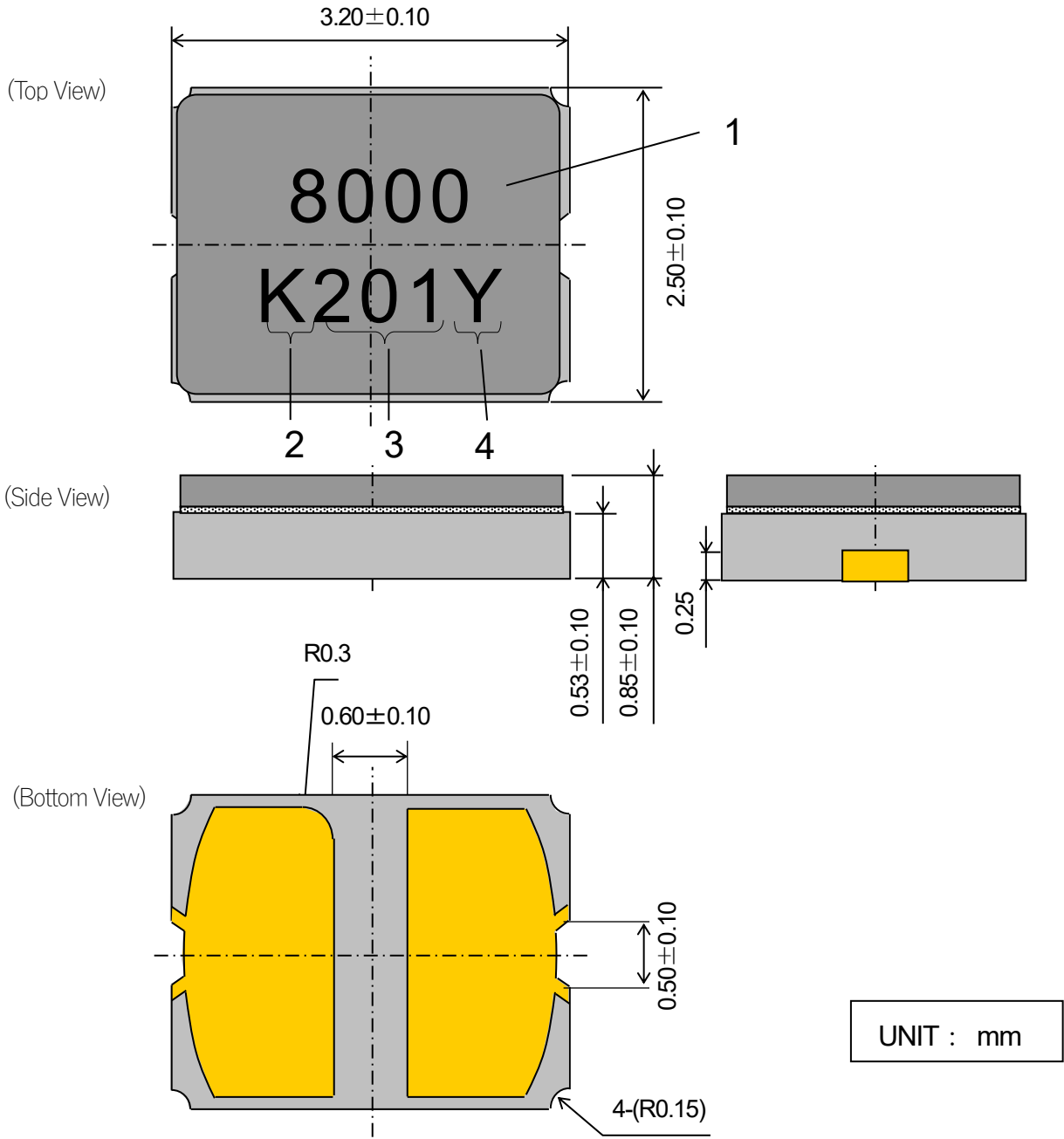

UNIT : mm

(2) MARKING

- 1. Nominal Frequency First 5 digits of the frequency is indicated.
- 2. Identification
- 3. Date Code Last 1 digit of YEAR and WEEK (Ex) 2022, Jan, 01 -> 201
- 4. Manufacturing Location Y...Japan (Yamagata)

Note: The font of marking is for reference only.

7 RECOMMENDED LAND PATTERN (not to scale)

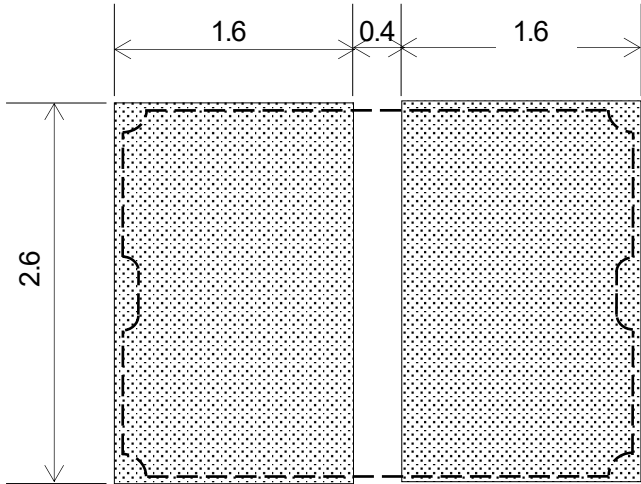

UNIT : mm

(5) Reel Specification

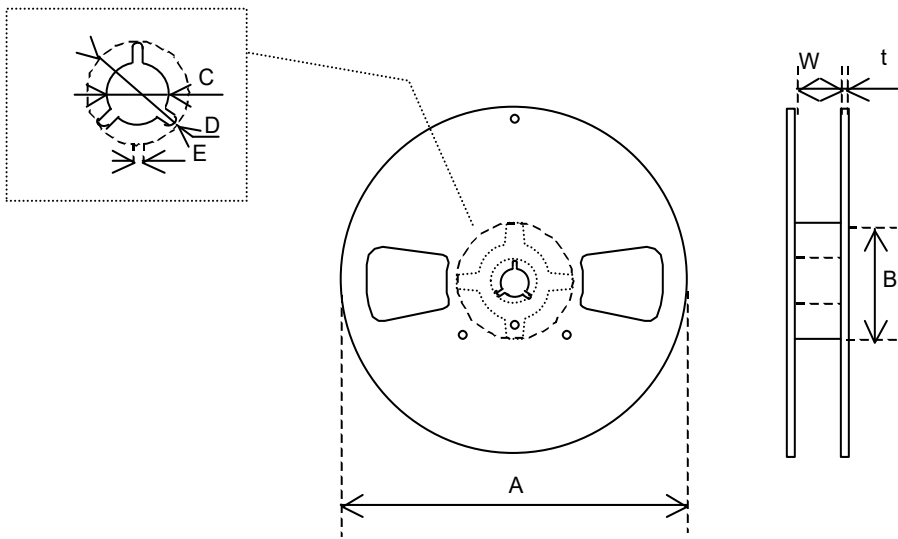

φ180 Reel (3,000pcs max.)

Symbol	A	B	C	D
Dimension	φ180 +0/-3	φ60 +1/-0	φ13±0.2	φ21±0.8
Symbol	E	W	t	
Dimension	2.0±0.5	9±1	2.0±0.5	

(Unit : mm)

9 ENVIRONMENTAL AND MECHANICAL CHARACTERISTICS :

(Reference: AEC-Q200 Rev. D. The solder used by examination is hereafter set to Sn-3Ag-0.5Cu.)

After following test, Frequency applies to each item and CI, $\pm 20\%$ or 5Ω of large value.

No	Stress	Reference	Additional Requirements
9.1	High Temperature Exposure (Storage)	MIL-STD-202 Method 108	1000 hrs. at rated operating temperature (e.g. 85°C part can be stored for 1000 hrs at 85°C. Same applies for 125°C). Unpowered. Measurement at 24 \pm 4 hours after test conclusion.
9.2	Temperature Cycling	JESD22 Method JA-104	1000 cycles (-40°C to 125°C) Note: If 85°C part the 1000 cycles will be at that temperature rating. Measurement at 24 \pm 4 hours after test conclusion. 30min maximum dwell time at each temperature extreme. 1 min. maximum transition time.
9.3	Biased Humidity	MIL-STD- 202 Method 103	1000 hours 85°C/85%RH. Rated VDD applied with 1 MW and inverter in parallel, 2X crystal CL capacitors between each crystal leg and GND. Measurement at 24 \pm 4 hours after test conclusion.
9.4	Operational Life	MIL-STD- 202 Method 108	Note: 1000 hrs @ 125°C. If 85°C part will be tested at that temperature. Rated VDD applied with 1 MW and inverter in parallel, 2X crystal CL capacitors between each crystal leg and GND. Measurement at 24 \pm 4 hours after test conclusion.
9.5	Terminal Strength (Leaded)	MIL-STD- 202 Method 211	Test leaded device lead integrity only. Conditions: A (227 g), C (227 g).
9.6	Resistance to Solvents	MIL-STD- 202 Method 215	Note: Also aqueous wash chemical - OKEM clean or equivalent. Do not use banned solvents.
9.7	Mechanical Shock	MIL-STD-202 Method 213	Figure 1 of Method 213. Condition C
9.8	Vibration	MIL-STD-202 Method 204	5g's for 20 minutes 12 cycles each of 3 orientations. Note: Use 8"X5" PCB .031" thick with 7 secure points on one 8" side and 2 secure points on corners of opposite sides. Parts mounted within 2" from any secure point. Test from 10-2000 Hz.
9.9	Resistance to Soldering Heat	MIL-STD-202 Method 210	Condition B No pre-heat of samples. Note: Single Wave solder - Procedure 1 with solder within 1.5 mm of device body for Leaded. Procedure 1 except 230°C and immerse only to level to cover terminals for SMD.
9.10	Solder ability	J-STD-002	For both Leaded & SMD. Electrical Test not required. Magnification 50 X. Conditions: Leaded: Method A @ 235°C, category 3. SMD: a) Method B, 4 hrs @ 155°C dry heat @ 235°C b) Method B @ 215°C category 3. c) Method D category 3 @ 260°C.
9.11	Flammability	UL-94	V-0 or V-1 Acceptable
9.12	Board Flex	AEC Q200-005	60 sec minimum holding time.
9.13	Terminal Strength (SMD)	AEC Q200-006	-

10 SOLDERING CONDITION

- (1) Material of solder
Kind ... lead free solder paste
Melting point ... $+220\pm 5^{\circ}\text{C}$
- (2) Reflow temp.profile

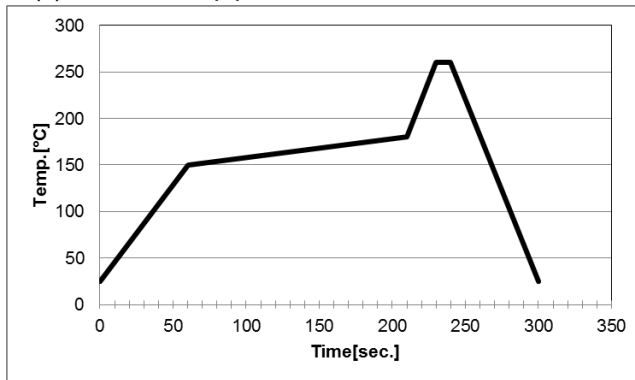

	Temp [°C]	Time[sec]
Preheating	+150 to +180	150 (typ.)
Peak	+260±5	10 (max.)
Total	—	300 (max.)

- (3) Hand Soldering
+350°C 3 sec max.
- (4) Reflow Times
2 times

11 CAUTIONS FOR USE

- (1) Soldering upon mounting
There is a possibility to influence product characteristics when solder paste or conductive glue comes in contact with product lid or surface.
- (2) When using mounting machine
Please minimize the shock when using mounting machine to avoid any excess stress to the product.
- (3) Conformity of a circuit
We strongly recommend to make sure that Negative resistance (Gain) of IC is designed to be 10 times the ESR (Equivalent Series Resistance) of crystal unit.
- (4) After making the Quartz Crystal mount on a printed circuit board, if it is required to divide the printed circuit board into another one, use it with attentive confirmation so that a warp caused by this dividing might not affect any damage. When designing a printed circuit board as well as handling the mounting As much as possible. The quartz crystal shall be passed through the reflow furnace. Then it shall be subjected to standard atmospheric conditions, after which cleaning shall be made.

12 STORAGE CONDITIONS

Please store product in below conditions, and use within 6 months.
Temperature +18 to +30°C, and Humidity of 20 to 70 % in the packaging condition.

13 MANUFACTURING LOCATION

KYOCERA Corporation Yamagata Higashine Plant / Japan (Yamagata)

14 Quality Assurance

To be guaranteed by KYOCERA Corporation Yamagata Higashine Plant Quality Assurance Division

15 Quality guarantee

In case when KYOCERA Corporation rooted failure occurred within 1 year after its delivery, substitute product will be arranged based on discussion. Quality guarantee of product after 1 year of its delivery is waived.

16 Others

In case of any questions or opinions regarding the Specification, please have it in written manner within 45 days after issued date.