

1. 適用範囲

本仕様書は、8 2 8 3 RECEPTACLE HOUSING の袋詰め梱包に適用する。

2. 対象製品型番 2 / 2 頁参照

3. 梱包副資材 2 / 2 頁参照

4. 梱包方法

図 1. 製品 1,000 + 2 個をポリ袋に収納し、口をシールして現品票を貼付する。

図 2. 外装箱底部に緩衝材を敷いた後、指定数量のポリ袋を外装箱に収納しフタを閉じてガムテープで止め、側面に現品票を貼付する。

現品票記入項目 対象型番
ロット番号
数量

1. Scope

This specifies carton packaging of series 8283 RECEPTACLE HOUSING.

2. Part number of applicable products (See page 2/2)

3. Packaging material (See page 2/2)

4. Packaging method

Fig.1 Seal up 1,000 + 2pcs in the plastic bag and stick a slip on the top.

Fig.2 Lay the air cap at the bottom of outer carton.
Pack vinyl in the outer carton referring to the page 2.
Fix the outer carton with an adhesive tape.
Stick a slip on the side of outer carton.

☆A slip shall be filled in the part number, lot number and Q'ty.

REV.	CONTENTS	EDN/DCN	DATE	ISSUE	CHECKED	APPROVED
O	INITIAL VERSION	EDN-229	01/04/13	M.KANEKO		Y.KOSHIMIZU
A	CHANGE OF PACKAGING	DCN-394	01/04/25	M,KANEKO	Y,KOSHIMIZU	M,ICHIHARA
B	Postscript	DCN-686	15/06/24	Y,Nakamura	N,Takahashi	Y,Ota

305-03-474

2.対象型番 P/N	3.梱包副資材 PACKAGING MATERIAL	P/N	Size	POS	Bag	Carton	POS	Bag	Carton
60 8283 3**8 45 ***	外装箱 (#4) Outer carton (#4)	95 9300 0018 20 004	424×214×H231	2P	1,000	70,000	10P	1,000	17,000
	ポリ袋 Vinyl	95 9300 0018 30 001	T0.05×270×160	3P	1,000	50,000	11P	1,000	15,000
			T0.05×250×350	4P	1,000	45,000	12P	1,000	13,000
				5P	1,000	40,000	13P	1,000	12,000
				6P	1,000	35,000	14P	1,000	12,000
				7P	1,000	30,000	15P	1,000	12,000
				8P	1,000	25,000	16P	1,000	12,000
				9P	1,000	20,000			

Fig 1

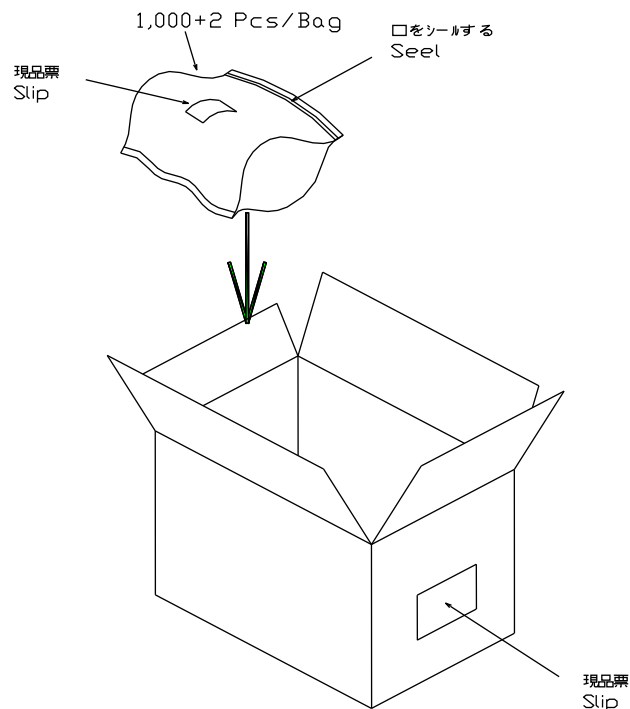
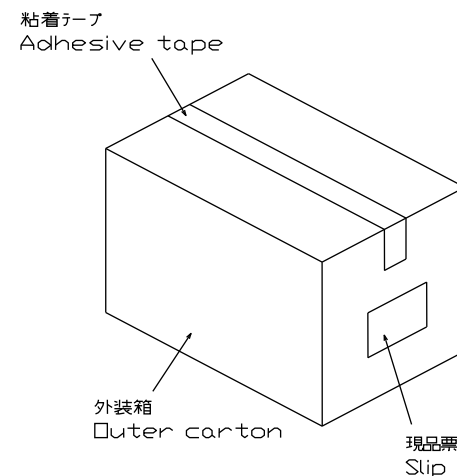

Fig 2



305-03-474