

2.対象型番 P/N	3.梱包副資材 PACKAGING MATERIAL			4.梱包収納数 Q'ty			
	PACKAGING MATERIAL	P/N	Size	Pos.	ビニール袋 Vinyl	内装箱 Inner C.	外装箱 Outer C.
60 9069 900 708 800 *	外装箱 Outer carton	95 9300 0018 20 003	259×214×H229	6 P	500	500	5,000
60 9069 900 710 800 *	内装箱 Inner carton	95 9300 0018 20 039	200×125×H40	8,10 P	300	300	3,000
60 9069 900 808 800 *	ビニール袋 Vinyl	95 9300 0018 30 005	150×250×T0.05				
60 9069 905 706 800 *							

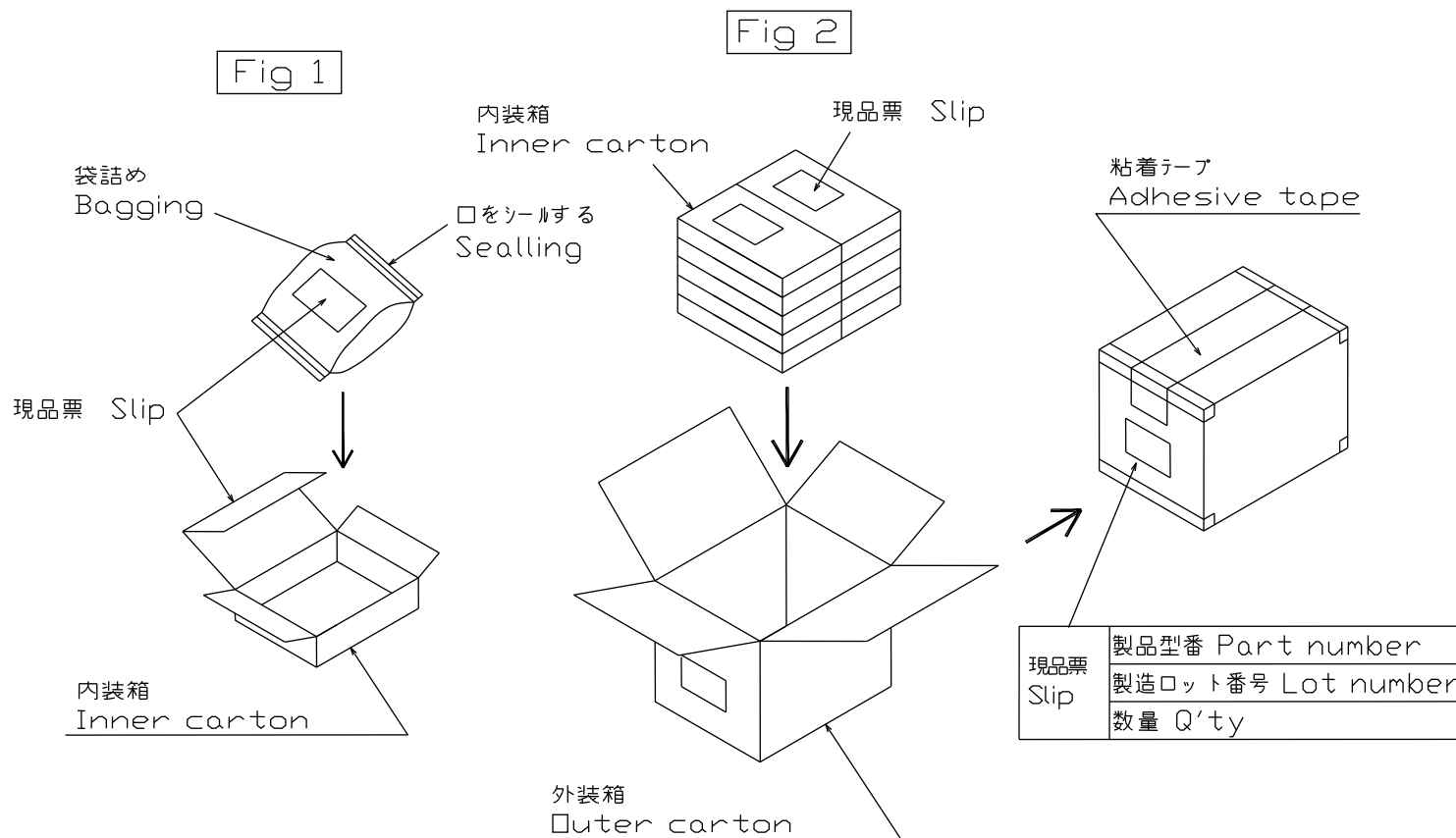

305-03-064