

NO.	DESCRIPTION	PART NO.	QTY	MATERIAL	DRW NO.	REMARKS
-----	-------------	----------	-----	----------	---------	---------

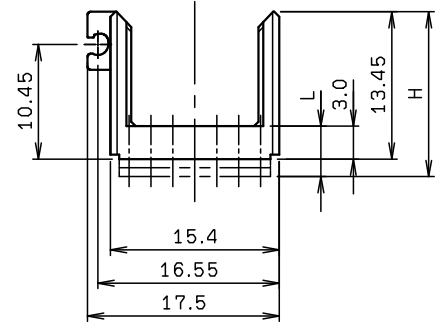
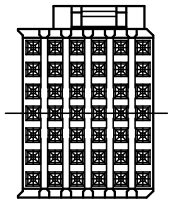
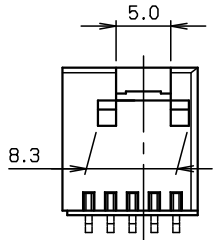
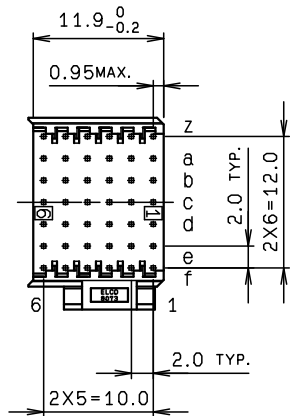

型番構成 P/N

61 8073 042 XXX 007

種 数 NO. OF POS. 042 : (5+2) X 6 = 42 POS.

バリエーション VARIATION

バリエーションコード VARIATION CODE	L	H	適合基板厚 PCB THICKNESS
300	3.0	13.45	t=4.8mm
310	3.8	14.25	t=4.0mm
320	4.6	15.05	t=3.2mm

注 記 NOTE

1. 材質 MATERIAL : ガラス入りPBT樹脂 (GF30%), UL94V-0, 色相: グレー
GLASS FILLED(30%)PBT, UL94V-0, COLOR: GRAY

© 2019 KYOCERA Corporation

ROHS規制対応
COMPLIANT WITH
ROHS REGULATIONS

TOLERANCE / 一般公差(S) ±0.3	PRODUCT SPEC / 製品規格		C	DCN19947	2019/09/11	R. ARAI	H. TAMAI	M. YOSHIDA
			B	DCN-399	1999/05/13	K. OHTAKA	K. NARITA	T. MORI
	UNIT	ANGLE	0	EDN-081	1999/02/02	K. OHTAKA	K. NARITA	T. MORI
	mm	3RD	NO.	EDN/DCN	DATE	ISSUE	CHECKED	APPROVED
SCALE	DATE	PART NAME / 品名						
2 : 1	1999/02/02	SERIES 8073 PLUG INS ST SHROUD WITH LATCH						
DRAWN	DESIGNED	CHECKED	APPROVED	PART NO. / 型番				
K. OHTAKA	K. OHTAKA	K. NARITA	T. MORI	61 8073 042 XXX 007				
KYOCERA				DWG NO. / 図番		SHEET/REV		
				BJS 8073603		1/1 C		

8 7 6 5 4 3 2 1