

NO.	DESCRIPTION	PART NO.	QTY	MATERIAL	DRW NO.	REMARKS
-----	-------------	----------	-----	----------	---------	---------

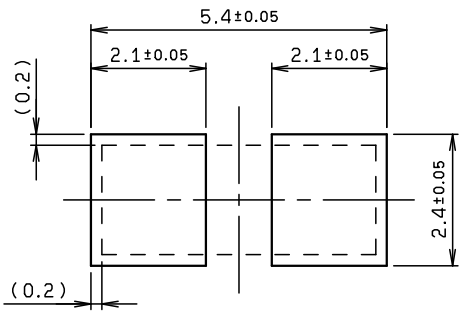

推奨パターンレイアウト
RECOMMENDED PATTERN LAYOUT

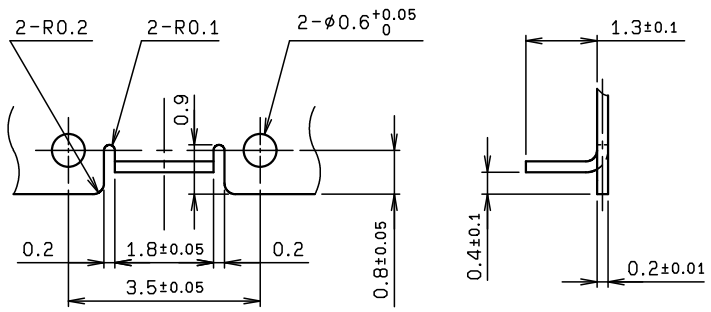
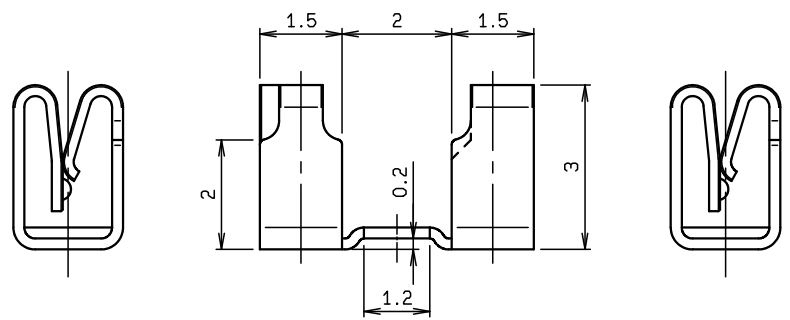
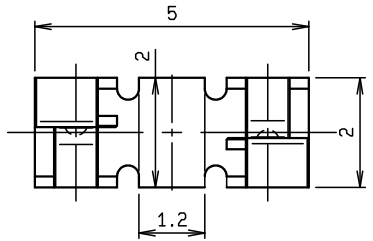

シールドケース形状
SHIELDING CASE FORM

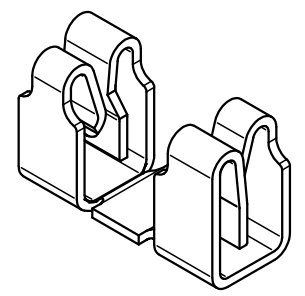
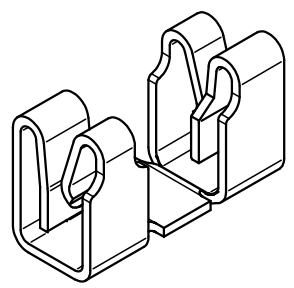

シールドロック斜視図
SHIELD LOCK

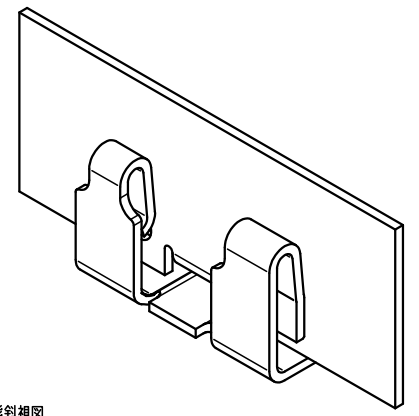
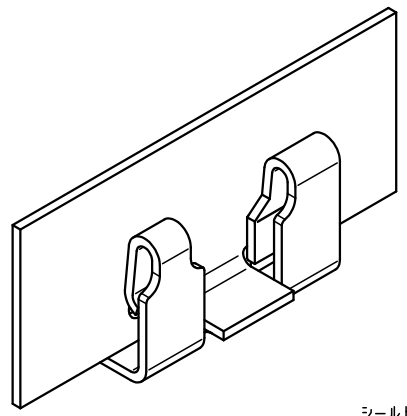

シールドロック嵌合状態斜視図
SHIELD LOCK MATING

ROHS規制対応
COMPLIANT WITH
ROHS REGULATIONS

TOLERANCE / 材質公差 (S)		PRODUCT SPEC / 製品規格		C	DCN-312	2017/03/22			
FINISH / 仕上げ		PHOS-BRONZE t0.2 PREPLATING Sn REFLOW		B	DCN-1052	2004/07/27	M. YOSHIDA	Y. SHIROYAMA	N. HAYASHI
		TOLERANCE / 一般公差		O	EDN-725	1999/11/04	K. KAKIUCHI		M. SAKAOKA
				NO.	EDN/DCN	DATE	ISSUE	CHECKED	APPROVED
				PART NAME / 品名					
				SERIES 8069 SHIELD LOCK					
UNIT	ANGLE	SCALE	DATE						
mm	3RD	10:1	1999/11/04						
DRAWN	DESIGNED	CHECKED	APPROVED	PART NO. / 型番					
K. KAKIUCHI	K. KAKIUCHI		M. SAKAOKA	70 8069 999 000 800 +					
KYOCERA KYOCERA Corporation				DWG NO. / 図番		SHEET/REV			
				BJS 8069501		1/1		C	

NO.	DESCRIPTION	PART NO.	QTY	MATERIAL	DRW NO.	REMARKS
1	SHIELD LOCK	70 8069 999 000 800 +	3000	PHOS-BRONZE		
2	EMBOSSED TAPE		1	POLYSTYRENE		
3	TOP COVER TAPE		1	POLYSTYRENE		
4	REEL		1	POLYSTYRENE		

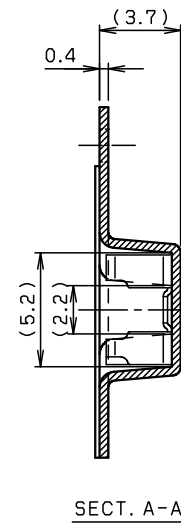
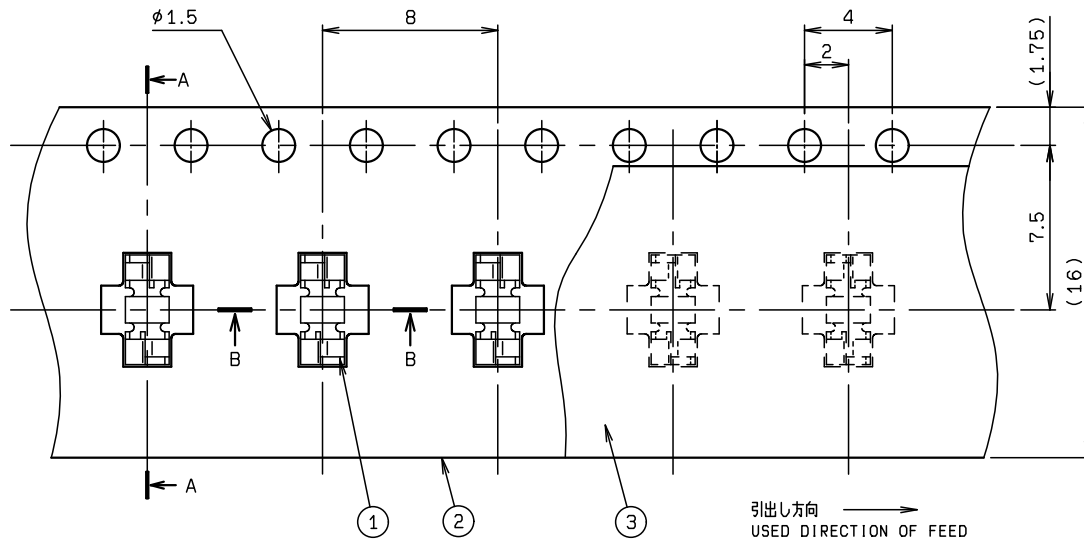

注記
NOTE

- 納入数量 : 3000個/リール
QUANTITY : 3000ea/reel
- 納入時のリール巻方向
REELING DIRECTION
IN DELIVERY

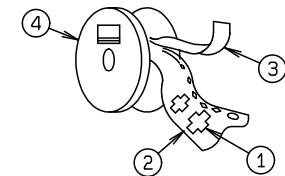

- 引出し方向
USER DIRECTION OF FEED

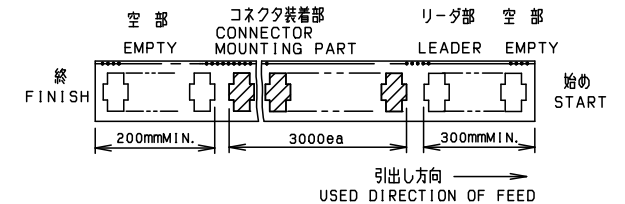

- 型番
P/N 04 8069 000 000 800 +

めっきコード
PLATING CODE

800 : 材料めっき
全体:CUストライク
Snリフローめっき 0.8~1.5μm
PRE-PLATED
ALL OVER:CU STRIKE
Sn REFLOW 0.8~1.5μm

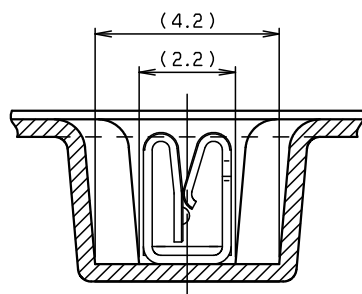

SECT. B-B (S=8:1)

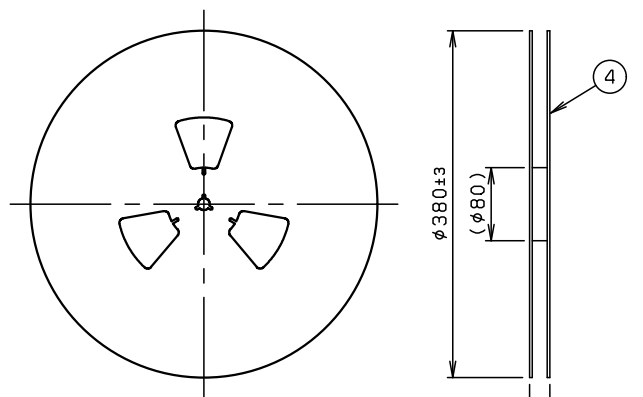

REEL DIMENTION (S=1:6)

ROHS規制対応
COMPLIANT WITH
ROHS REGULATIONS

TOLERANCE / 材質公差 (S)		PRODUCT SPEC / 製品規格		E	DCN-312	2017/03/22			
±0.3 / 仕上げ		TOLERANCE / 一般公差		D	DCN-1052	2004/07/27	M. YOSHIDA	Y. SHIROYAMA	N. HAYASHI
				O	EDN-710	1999/10/28	K. KAKIUCHI		M. SAKAOKA
				NO.	EDN/DCN	DATE	ISSUE	CHECKED	APPROVED
				PART NAME / 品名					
				SERIES 8069 SHIELD LOCK ASSY					
				16mm TAPING					
UNIT	ANGLE	SCALE	DATE	PART NO. / 型番					
mm	3RD	4 : 1	1999/10/28	04 8069 000 000 800 +					
DRAWN	DESIGNED	CHECKED	APPROVED	DWG NO. / 図番					
K. KAKIUCHI	K. KAKIUCHI		M. SAKAOKA	BJS 8069001					
KYOCERA		KYOCERA Corporation		SHEET/REV				1/1 E	