

NO.	DESCRIPTION	PART NO.	QTY	MATERIAL	DRW NO.	REMARKS
1	INSULATOR		1	LCP		UL94V-0 COLOR: WHITE(NATURAL)
2	CONTACT		N	PHOS-BRONZE		t=0.15 AU
3	ANCHOR PLATE		2	BRASS		t=0.15 Sn-Cu

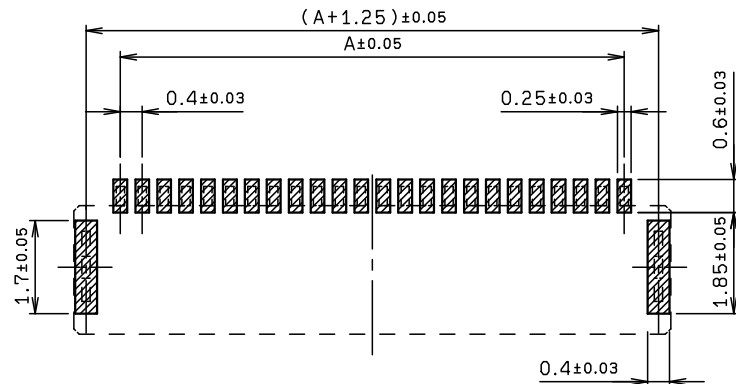
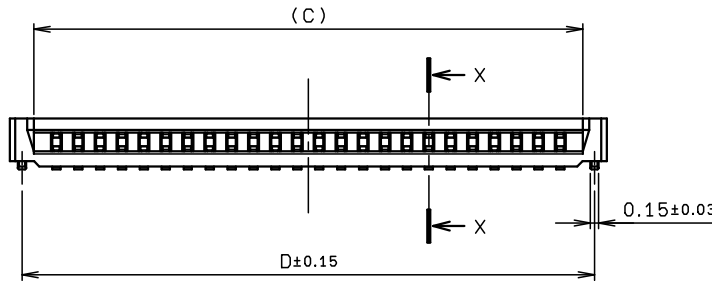
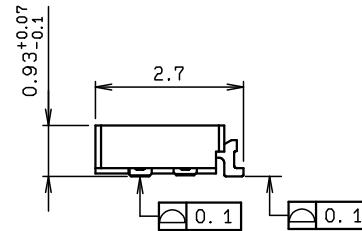
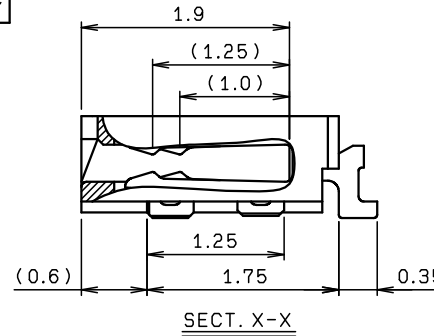
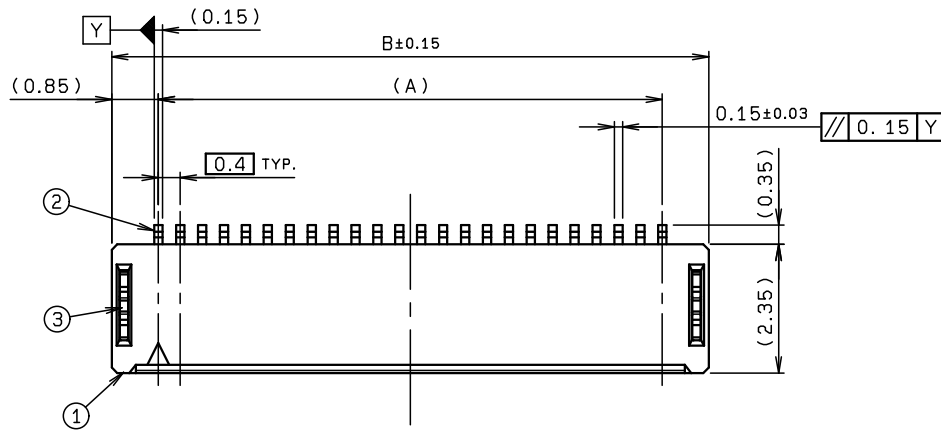

基板取付け寸法
MOUNTING LAYOUT

極数 NO. OF POS.	A	B	C	D
4	1.2	2.9	2.0	2.45
5	1.6	3.3	2.4	2.85
6	2.0	3.7	2.8	3.25
7	2.4	4.1	3.2	3.65
8	2.8	4.5	3.6	4.05
9	3.2	4.9	4.0	4.45
10	3.6	5.3	4.4	4.85
11	4.0	5.7	4.8	5.25
12	4.4	6.1	5.2	5.65
13	4.8	6.5	5.6	6.05
14	5.2	6.9	6.0	6.45
15	5.6	7.3	6.4	6.85
16	6.0	7.7	6.8	7.25
17	6.4	8.1	7.2	7.65
18	6.8	8.5	7.6	8.05
19	7.2	8.9	8.0	8.45
20	7.6	9.3	8.4	8.85
22	8.4	10.1	9.2	9.65

※この表は1, 2ページ目にのみ適用
※THIS CHART IS APPLICABLE TO SHEET-1 AND SHEET-2 ONLY.

注記
NOTE

1. コンタクトテール及び固定金具は基板より最大浮き0.1mmとする。
CONTACT TAIL AND ANCHOR PLATE HEIGHT SHALL BE 0.1MAX.

※この注記は1, 2ページ目にのみ適用
※THIS NOTES IS APPLICABLE TO SHEET-1 AND SHEET-2 ONLY.

ROHS規制対応
COMPLIANT WITH
ROHS REGULATIONS

TOLERANCE / 一般公差(S)		PRODUCT SPEC / 製品規格		B	DCN-1047	9-29-14			
X < 10	±0.2			A	DCN-699	5-20-13	Y. MANBA		Y. FUJII
10 ≤ X < 30	±0.25	UNIT	ANGLE	O	EDN-324	5-10-12	Y. MANBA		T. SATOH
30 ≤ X	±0.3	mm	3RD	NO.	EDN/DCN	DATE	ISSUE	CHECKED	APPROVED
ANGLE / 角度	±3°	SCALE	DATE	PART NAME / 品名					
		NTS	5-10-12	SERIES 6824 FPC FFC ASSY					
DRAWN	DESIGNED	CHECKED	APPROVED	0.4mm PITCH CONNECTOR H=0.93 LIF TYPE					
Y. MANBA	Y. MANBA		T. SATOH	PART NO. / 製番					
				04 6824 6XX 000 846 +					
				DWG NO. / 図番					
				BJS 6824002					
				SHEET/REV					
				1/3 B					

KYOCERA Corporation

NO.	DESCRIPTION	PART NO.	QTY	MATERIAL	DRW NO.	REMARKS
-----	-------------	----------	-----	----------	---------	---------

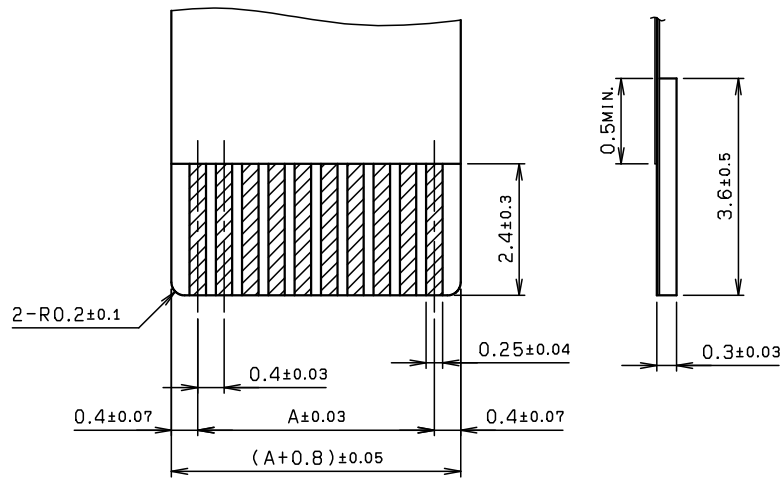

推奨FPC寸法
APPLICABLE FPC

FPC構成
FPC STRUCTURE
(推奨仕様)

表面処理	仕様
AUめっき AU PLATING	NI UNDER COAT: 3±2µm AU: 0.1µmMIN.

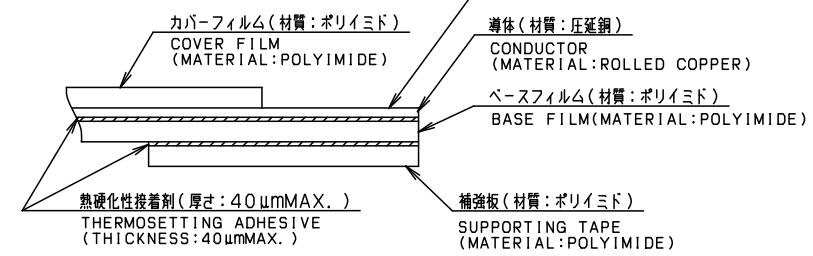

ROHS規制対応
COMPLIANT WITH
ROHS REGULATIONS

TOLERANCE / 一般公差 (S)		PRODUCT SPEC / 製品規格		REFER TO SHEET		1/3			
X < 10	±0.2	UNIT	ANGLE	NO.	EDN/DCN	DATE	ISSUE	CHECKED	APPROVED
10 ≤ X < 30	±0.25	mm	3RD	PART NAME / 品名					
30 ≤ X	±0.3	SCALE	DATE	SERIES 6824 FPC FFC ASSY					
ANGLE / 角度	±3°	NTS		0.4mm PITCH CONNECTOR H=0.93 LIF TYPE					
DRAWN	DESIGNED	CHECKED	APPROVED	PART NO. / 製番					
Y. MANBA	Y. MANBA		T. SATOH	04 6824 6XX 000 846 +					
KYOCERA KYOCERA Corporation				DWG NO. / 図番		SHEET/REV			
				BJS 6824002		2/3		B	

NO.	DESCRIPTION	PART NO.	QTY	MATERIAL	DRW NO.	REMARKS
1	CONNECTOR	04 6824 6XX 000 846 +	6000			00 6824 6XX 000 846 +
2	EMBOSSED TAPE		1	POLYSTYRENE		
3	TOP COVER TAPE		1	POLYSTYRENE		
4	REEL		1	POLYSTYRENE		

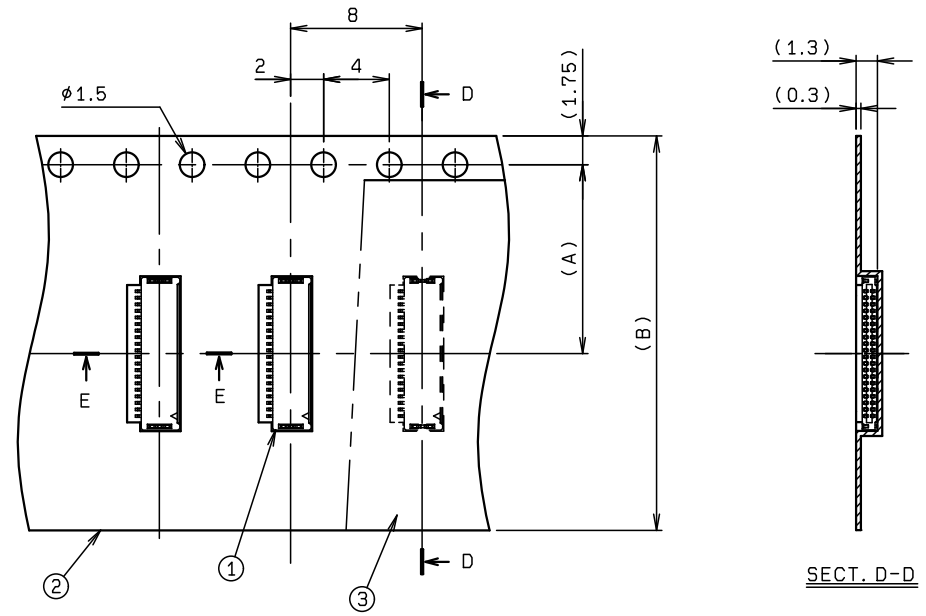

種数 NO. OF POS.	A	B	C
4	7.5	16.0	22.4
5	7.5	16.0	22.4
6	7.5	16.0	22.4
7	7.5	16.0	22.4
8	7.5	16.0	22.4
9	7.5	16.0	22.4
10	7.5	16.0	22.4
11	7.5	16.0	22.4
12	7.5	16.0	22.4
13	7.5	16.0	22.4
14	7.5	16.0	22.4
15	7.5	16.0	22.4
16	11.5	24.0	30.4
17	11.5	24.0	30.4
18	11.5	24.0	30.4
19	11.5	24.0	30.4
20	11.5	24.0	30.4
22	11.5	24.0	30.4

※この表は3ページ目のみ適用
 ※THIS CHART IS APPLICABLE TO SHEET-3 ONLY.

注記
NOTE

- 梱包数量 : 6000 個/リール
PACKING QUANTITY : 6000 ea/reel
- 納入時のリール巻き方向
REELING DIRECTION IN DELIVERY

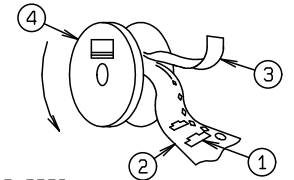

- 引出し方向
USER DIRECTION OF FEED.

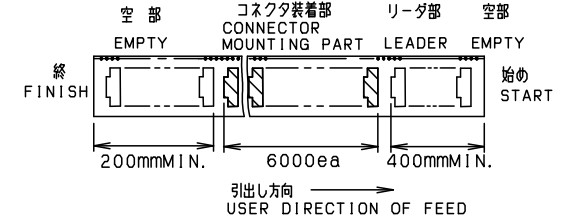

- 型番
P/N 04 6824 6XX 000 846 +

種数
NO. OF POS.

※この注記の1~3は3ページ目のみ適用
 ※THIS NOTES 1 TO 3 ARE APPLICABLE TO SHEET-3 ONLY.

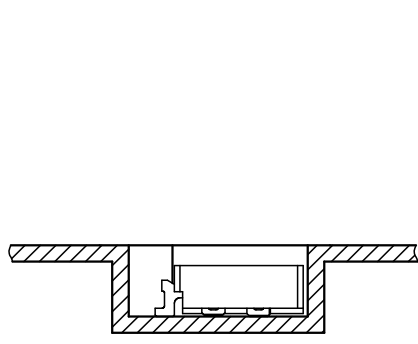

SECT. E-E (S=10/1)

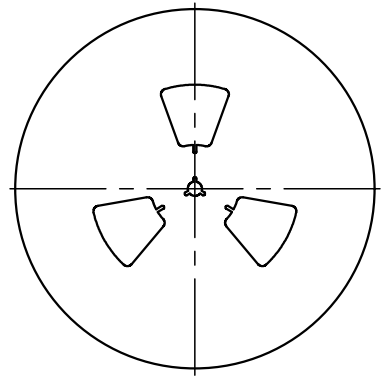

REEL DIMENSION (S=1/5)

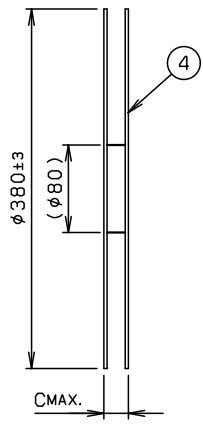

ROHS規制対応
COMPLIANT WITH
ROHS REGULATIONS

TOLERANCE / 一般公差 (S)		PRODUCT SPEC / 製品規格		REFER TO SHEET 1/3		NO.		EDN/DCN		DATE		ISSUE		CHECKED		APPROVED	
10 ≤ X < 30	±0.25	UNIT	ANGLE	mm	3RD	PART NAME / 品名		SERIES 6824 EMBOSS TAPE ASSY									
30 ≤ X	±0.3	SCALE	DATE	2 : 1	5-10-12	0.4mm PITCH CONNECTOR H=0.93 LIF TYPE											
DRAWN Y. MANBA		DESIGNED Y. MANBA		CHECKED		APPROVED T. SATOH		PART NO. / 製番 04 6824 6XX 000 846 +									
DRAWN		DESIGNED		CHECKED		APPROVED		DWG NO. / 図番 BJS 6824002									
Y. MANBA		Y. MANBA		T. SATOH		T. SATOH		SHEET/REV 3/3 B									
KYOCERA		KYOCERA Corporation															