

種類 KIND	公差 TOLERANCE		
	P	W	M
FPC	±0.02	+0.07 -0.05	±0.05
FFC	±0.05	±0.03	±0.1

適用FPC/FFC寸法  
APPLICABLE FPC/FFC

NO.	DESCRIPTION	PART NO.	QTY	MATERIAL	DRW NO.	REMARKS
1	INSULATOR		1	HEAT RESISTING PLASTIC		COLOR: BROWN
2	ACTUATOR		1	HEAT RESISTING PLASTIC		COLOR: BLACK
3	CONTACT		N	PHOS-BRONZE		t=0.25 Sn-Cu PLATING
4	ANCHOR PLATE		2	PHOS-BRONZE		t=0.25 Sn-Cu PLATING

種数 NO. OF POS	A	B	C	D	E
5	4.0	6.2	12.2	11.9	12.6
6	5.0	7.2	13.2	12.9	13.6
7	6.0	8.2	14.2	13.9	14.6
8	7.0	9.2	15.2	14.9	15.6
9	8.0	10.2	16.2	15.9	16.6
10	9.0	11.2	17.2	16.9	17.6
11	10.0	12.2	18.2	17.9	18.6
12	11.0	13.2	19.2	18.9	19.6
13	12.0	14.2	20.2	19.9	20.6
14	13.0	15.2	21.2	20.9	21.6
15	14.0	16.2	22.2	21.9	22.6
16	15.0	17.2	23.2	22.9	23.6
17	16.0	18.2	24.2	23.9	24.6
18	17.0	19.2	25.2	24.9	25.6
19	18.0	20.2	26.2	25.9	26.6
20	19.0	21.2	27.2	26.9	27.6
21	20.0	22.2	28.2	27.9	28.6
22	21.0	23.2	29.2	28.9	29.6
23	22.0	24.2	30.2	29.9	30.6
24	23.0	25.2	31.2	30.9	31.6
25	24.0	26.2	32.2	31.9	32.6
26	25.0	27.2	33.2	32.9	33.6
27	26.0	28.2	34.2	33.9	34.6
28	27.0	29.2	35.2	34.9	35.6
29	28.0	30.2	36.2	35.9	36.6
30	29.0	31.2	37.2	36.9	37.6

※この表は1ページ目のみ適用  
※THIS CHART IS APPLICABLE TO SHEET-1 ONLY.

ROHS規制対応  
COMPLIANT WITH  
ROHS REGULATIONS

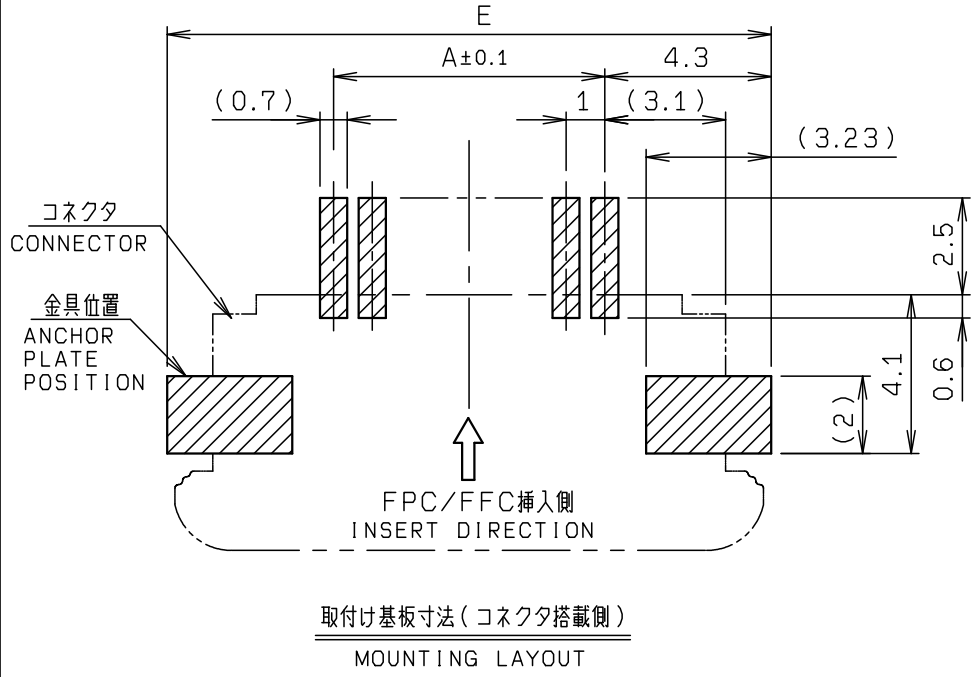

TOLERANCE / 一般公差(S)		PRODUCT SPEC / 製品規格		E DCN25194 2025/05/13 R. NAKAJIMA Y. TSURUOKA H. TAMAI		
X < 10	±0.2	UNIT		D DCN21831 2021/12/20 S. MORITA H. LU A. TSUNEMURA		
10 ≤ X < 30	±0.25	mm	ANGLE	O EDN-1017 2003/12/26 T. SATOH K. ONO		
30 ≤ X	±0.3		3RD	NO. EDN/DCN DATE ISSUE CHECKED APPROVED		
ANGLE / 角度 ±3°		SCALE	DATE	PART NAME / 品名		
		5 : 1	2003/12/26	SERIES 6224 FPC FFC ASSY		
DRAWN	DESIGNED	CHECKED	APPROVED	1mm PITCH CONN. (WITH ANCHOR PLATE)		
LI	T. SATOH		K. ONO	PART NO. / 型番		
<b>KYOCERA</b>				08 6224 OXX 001 800 +		
				DWG NO. / 図番		
				BJS 6224045		
				SHEET / REV		
				1 / 2		E

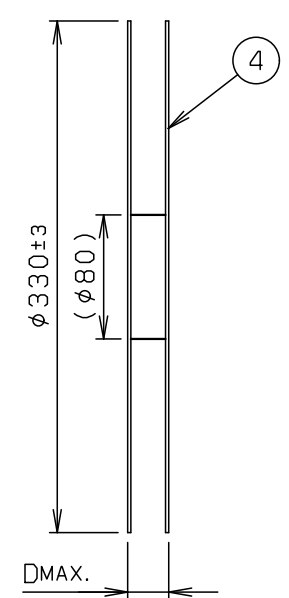
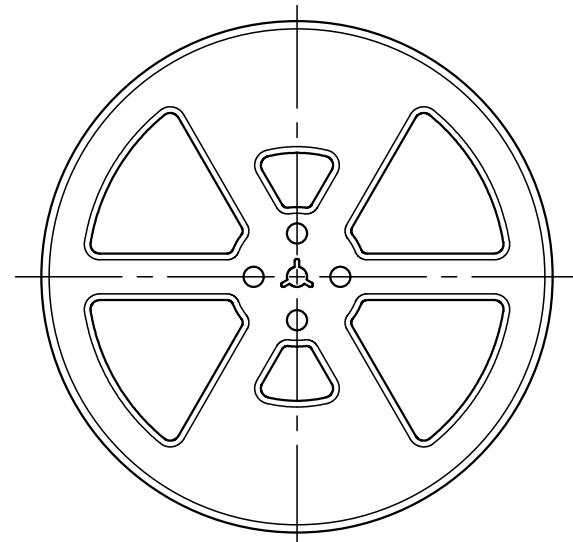
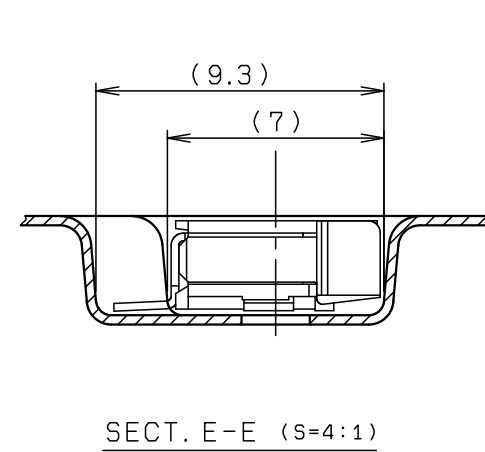
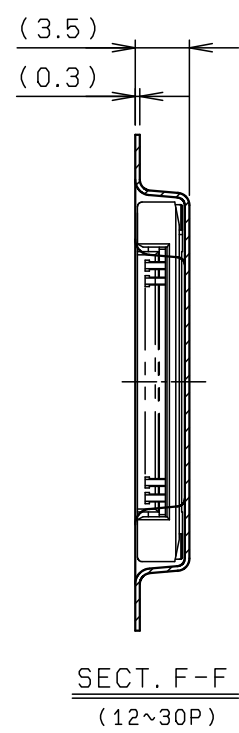
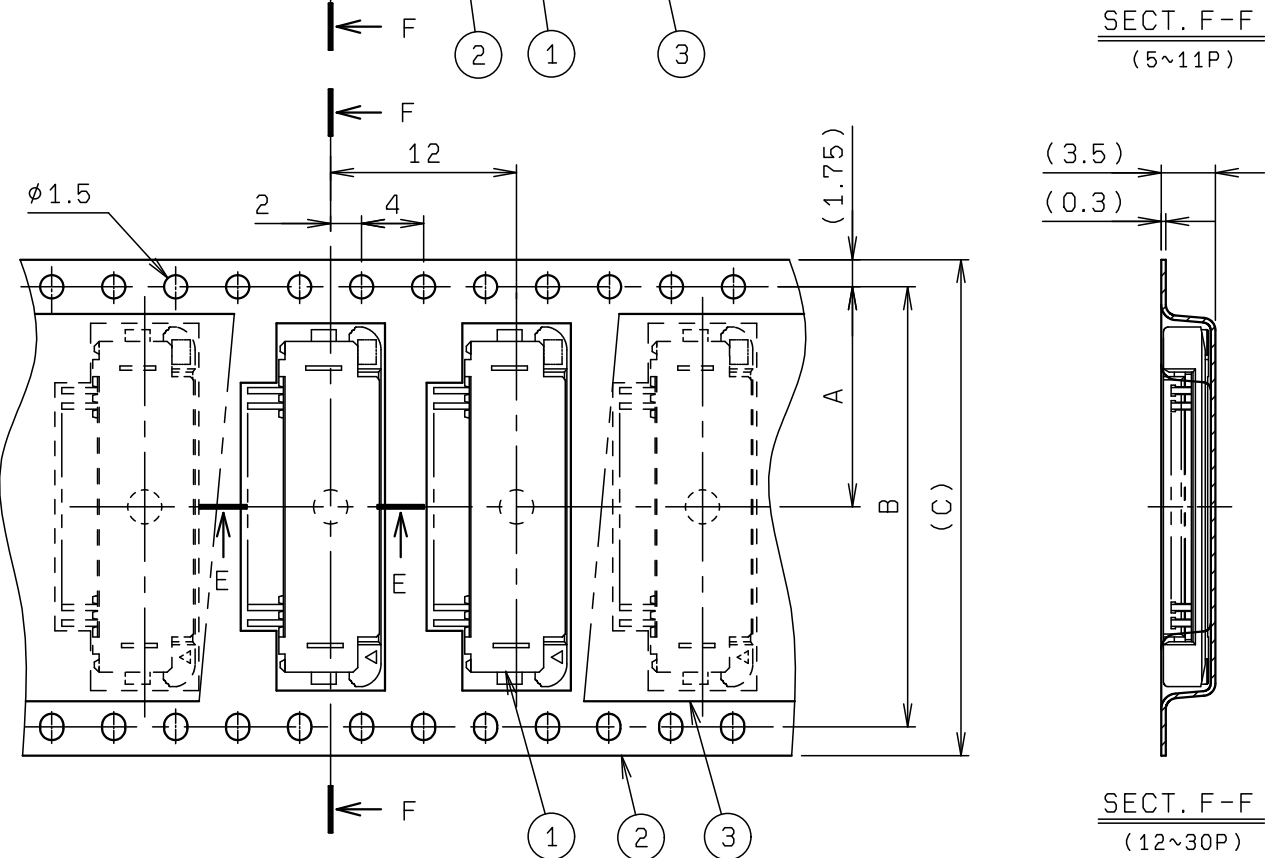
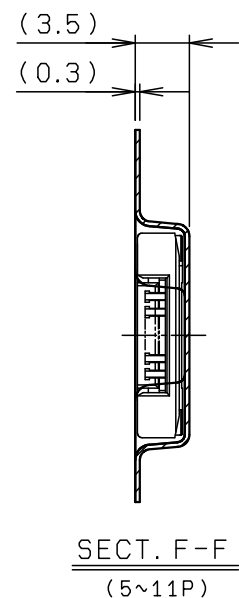
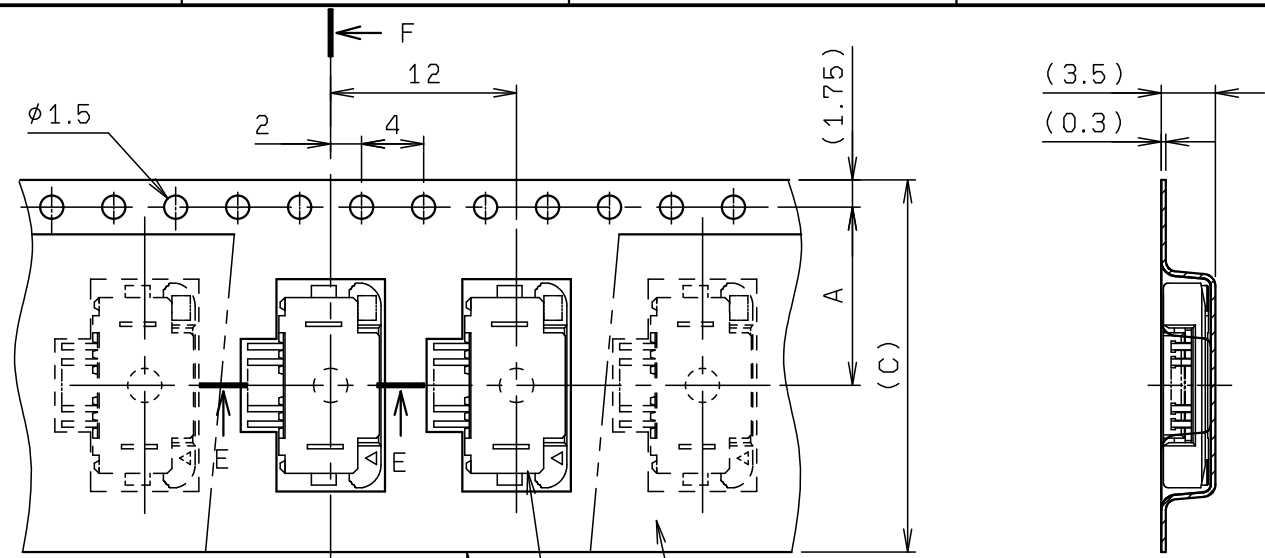

REEL DIMENSION (S=1:5)

NO.	DESCRIPTION	PART NO.	QTY	MATERIAL	DRW NO.	REMARKS
1	CONNECTOR	08 6224 OXX 001 800 +	1000			00 6224 OXX 001 800 +
2	EMBOSSED TAPE		1	POLYSTYRENE		
3	TOP COVER TAPE		1	POLYSTYRENE		
4	REEL		1	POLYSTYRENE		

注記  
NOTE

- 梱包数量 : 1000 個/リール  
PACKING QUANTITY : 1000 ea/reel
- 納入時のリール巻き方向  
REELING DIRECTION IN DELIVERY

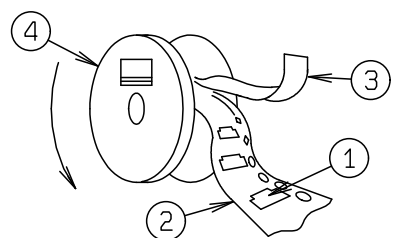

- 引出し方向  
USER DIRECTION OF FEED

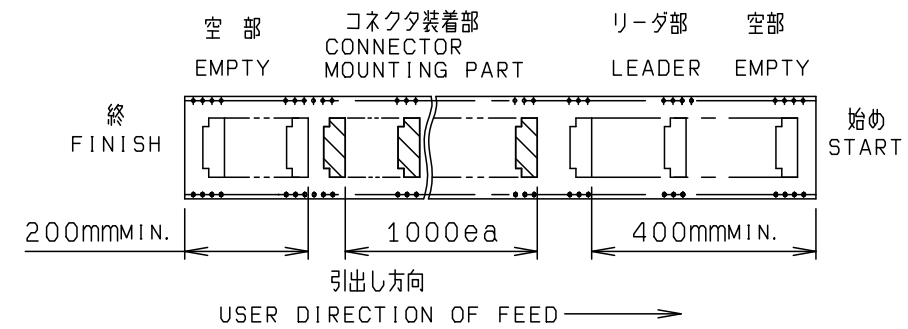

- 型番  
P/N 08 6224 OXX 001 800 +  
種数 NO OF POS. ————  
バリエーション VARIATION ————  
1: リフロー-金具材料めっき仕様  
REFLOW METAL PLATING BEFORE STAMPING  
めっき PLATING ————  
+ : Sn-Cu

※この注記の1~3は2ページ目のみ適用  
※THESE NOTES 1 TO 3 ARE APPLICABLE TO SHEET-2 ONLY.

種数 NO. OF POS.	A	B	C	D
5	11.5	—	24.0	30.4
6	11.5	—	24.0	30.4
7	11.5	—	24.0	30.4
8	11.5	—	24.0	30.4
9	11.5	—	24.0	30.4
10	11.5	—	24.0	30.4
11	11.5	—	24.0	30.4
12	14.2	28.4	32.0	38.4
13	14.2	28.4	32.0	38.4
14	14.2	28.4	32.0	38.4
15	14.2	28.4	32.0	38.4
16	14.2	28.4	32.0	38.4
17	20.2	40.4	44.0	50.4
18	20.2	40.4	44.0	50.4
19	20.2	40.4	44.0	50.4
20	20.2	40.4	44.0	50.4
21	20.2	40.4	44.0	50.4
22	20.2	40.4	44.0	50.4
23	20.2	40.4	44.0	50.4
24	20.2	40.4	44.0	50.4
25	20.2	40.4	44.0	50.4
26	20.2	40.4	44.0	50.4
27	20.2	40.4	44.0	50.4
28	26.2	52.4	56.0	62.4
29	26.2	52.4	56.0	62.4
30	26.2	52.4	56.0	62.4

※生産対応可能種数については、営業部に  
ご確認ください。  
PLEASE ASK SALES DEPARTMENT  
WHAT NUMBER OF CONTACT CAN  
BE PRODUCED.

※この表は2ページ目のみ適用  
※THIS CHART IS APPLICABLE TO  
SHEET-2 ONLY.

ROHS規制対応  
COMPLIANT WITH  
ROHS REGULATIONS

TOLERANCE / 一般公差(S)		PRODUCT SPEC / 製品規格		REFER TO SHEET 1/2	
X < 10	±0.2	UNIT	ANGLE	NO.	EDN/DCN
10 ≤ X < 30	±0.25	mm	3RD	DATE	ISSUE
30 ≤ X	±0.3	SCALE	DATE	CHECKED	APPROVED
ANGLE / 角度	±3°	2 : 1	2003/12/26	PART NAME / 品名	
DRAWN	DESIGNED	CHECKED	APPROVED	SERIES 6224	
LI	T. SATOH		K. ONO	EMBOSS TAPE ASSY	
DRAWN				PART NO. / 型番	
LI				08 6224 OXX 001 800 +	
DESIGNED				DWG NO. / 図番	
T. SATOH				BJS 6224045	
CHECKED				SHEET/REV	
				12/2 E	
APPROVED					
K. ONO					

