

NO.	DESCRIPTION	PART NO.	QTY	MATERIAL	DRW NO.	REMARKS
1	INSULATOR		1	LCP		COLOR:BLACK UL94V-0
2	CONTACT		N	COPPER ALLOY		Au, Be-Free
3	ANCHOR PLATE		2	COPPER ALLOY		Au, Be-Free

種数 NO. OF POS.	A	B	C	D	E
24	3.85	5.55	6.55	4.95	5.45
30	4.9	6.6	7.6	6.0	6.5
40	6.65	8.35	9.35	7.75	8.25
50	8.4	10.1	11.1	9.5	10.0
60	10.15	11.85	12.85	11.25	11.75

※この表は1ページ目のみ適用
 ※THIS CHART IS APPLICABLE TO SHEET-1 ONLY.

注記
 NOTE

① テール及び金具底面の相互の輪郭度は、0.08MAX.
 COPLANARITY OF CONTACT TAIL
 AND ANCHOR PLATE IS 0.08MAX.

② 図示の位置にLOT NO. を刻印する。(レーザー)
 LOT NO. SHALL BE MARKED
 AT THE SPECIFIED POSITION. (LASER)

K 3 01 S
 工場コード
 製造日 1, 2, ~29, 30, 31.
 製造月 1, 2, ~9, X, Y, Z.
 「K」表示(固定)

※この注記は1ページ目のみ適用
 ※THIS NOTE IS APPLICABLE TO
 SHEET-1 ONLY.

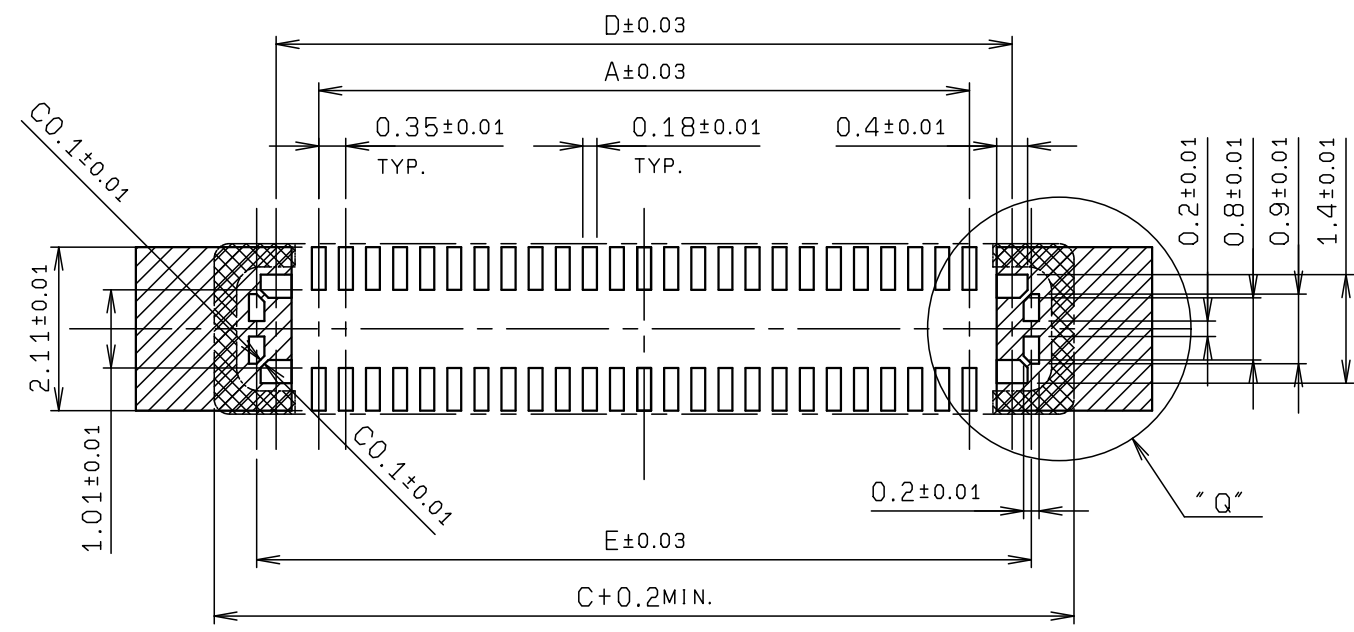
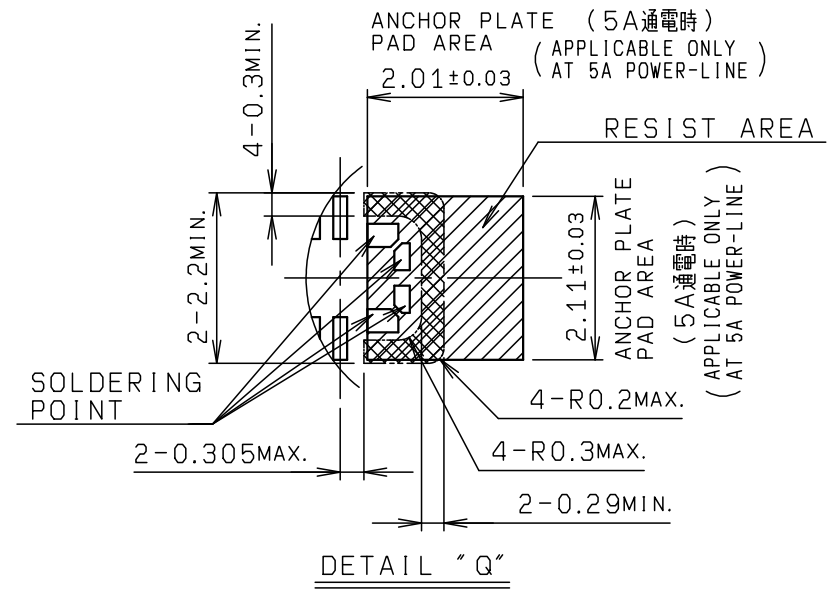
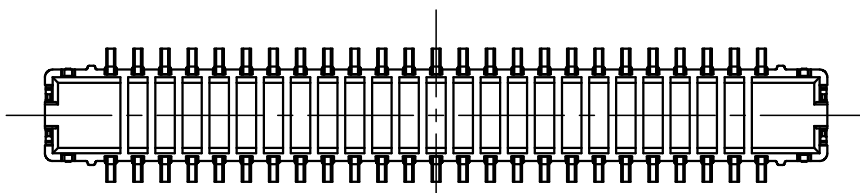
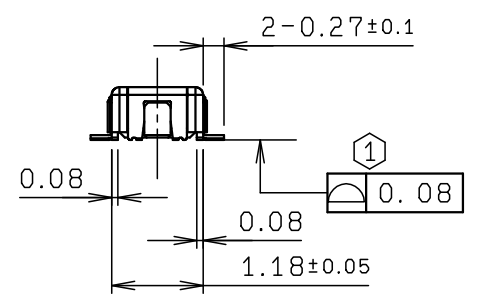
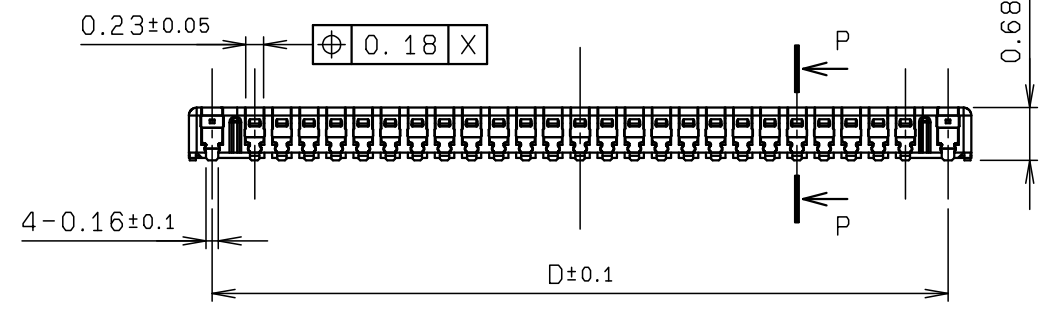
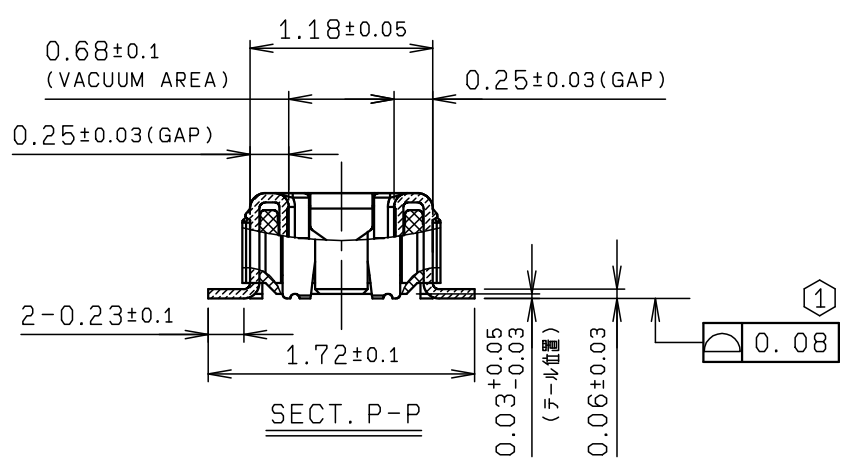
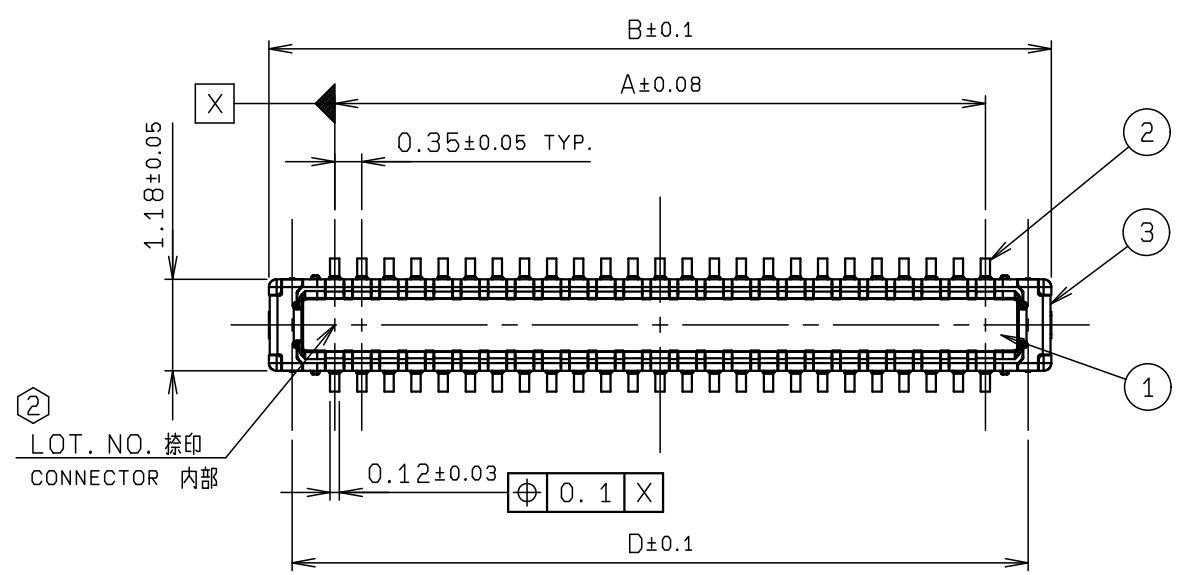

MOUNTING LAYOUT
 [Hatched Box] : 絶縁エリア
 INSULATION AREA

ROHS規制対応
 COMPLIANT WITH
 ROHS REGULATIONS

TOLERANCE / 一般公差(S)		PRODUCT SPEC / 製品規格		H DCN24077 2024/02/05 H. LU		S. HORINO	
X < 10	±0.2	UNIT	ANGLE	G DCN24053 2024/01/30 K. SHIOBARA H. LU	S. HORINO		
10 ≤ X < 30	±0.25	mm	3RD	O EDN-183 2015/05/10 G. IKEDA K. HIRATA K. YAMANE			
30 ≤ X	±0.3	SCALE	DATE	NO. EDN/DCN DATE ISSUE CHECKED APPROVED			
ANGLE / 角度	±3°	NTS	2015/05/10	PART NAME / 品名			
				SERIES 5863 PLUG ASSY			
				0.35mm PITCH BOARD TO BOARD H=0.8			
DRAWN	DESIGNED	CHECKED	APPROVED	PART NO. / 型番			
G. IKEDA	G. IKEDA	K. HIRATA	K. YAMANE	14 5863 XXX 024 829 +			
DWG NO. / 図番				SHEET/REV			
BJS 5863007				11/2 H			

NO.	DESCRIPTION	PART NO.	QTY	MATERIAL	DRW NO.	REMARKS
1	CONNECTOR	14 5863 XXX 024 829 +	15000			10 5863 XXX 024 829 +
2	EMBOSSED TAPE		1	POLYSTYRENE		
3	TOP COVER TAPE		1	PET		
4	REEL		1	POLYSTYRENE		

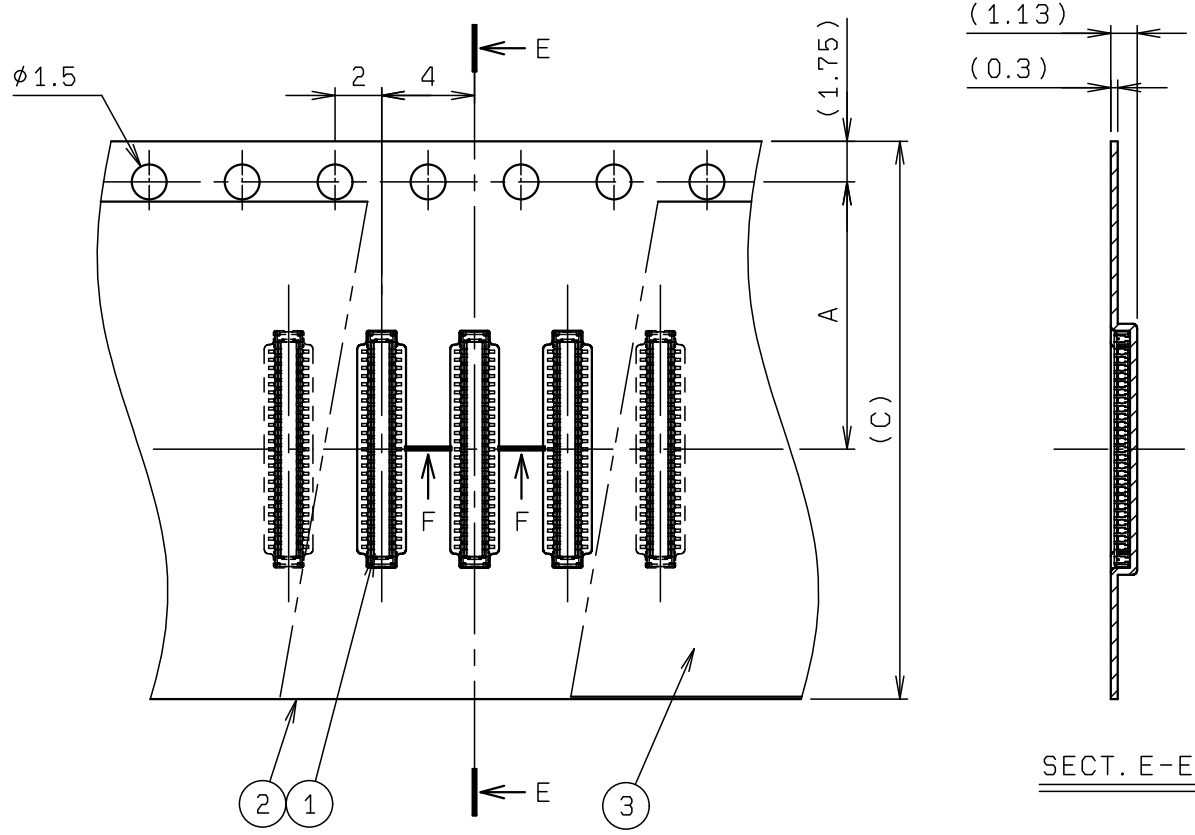

極数 NO. OF POS.	A	B	C	D
24	7.5	-	16.0	22.4
30	7.5	-	16.0	22.4
40	11.5	-	24.0	30.4
50	11.5	-	24.0	30.4
60	11.5	-	24.0	30.4

※この表は2ページ目にも適用
 ※THIS CHART IS APPLICABLE TO SHEET-2 ONLY.

注記
NOTE

1. 梱包数量: 15000 個/リール
 PACKING QUANTITY: 15000 ea/reel

2. 納入時のリール巻き方向
 REELING DIRECTION IN DELIVERY

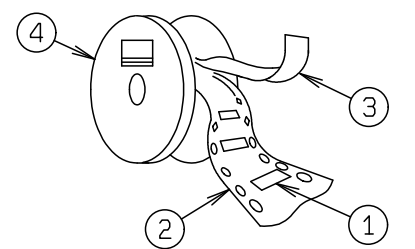

3. 引出し方向
 USER DIRECTION OF FEED

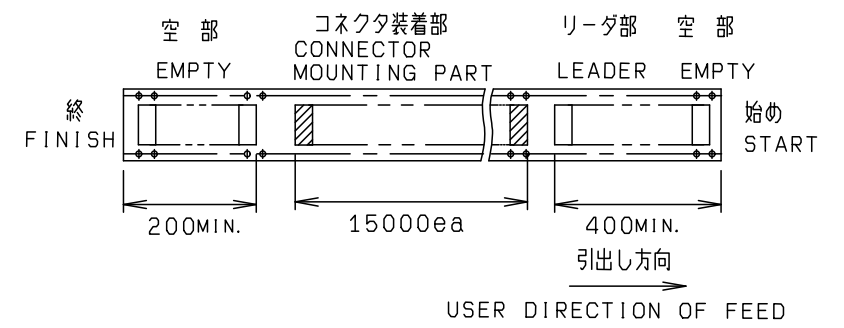

4. 型番
 P/N 14 5863 XXX 024 829 +
 極数
 NO. OF POS.

※この注記の1~4は2ページ目にも適用
 ※THESE NOTES 1 TO 4 ARE APPLICABLE TO SHEET-2 ONLY.

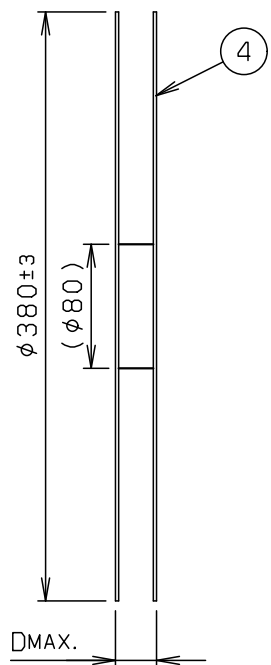
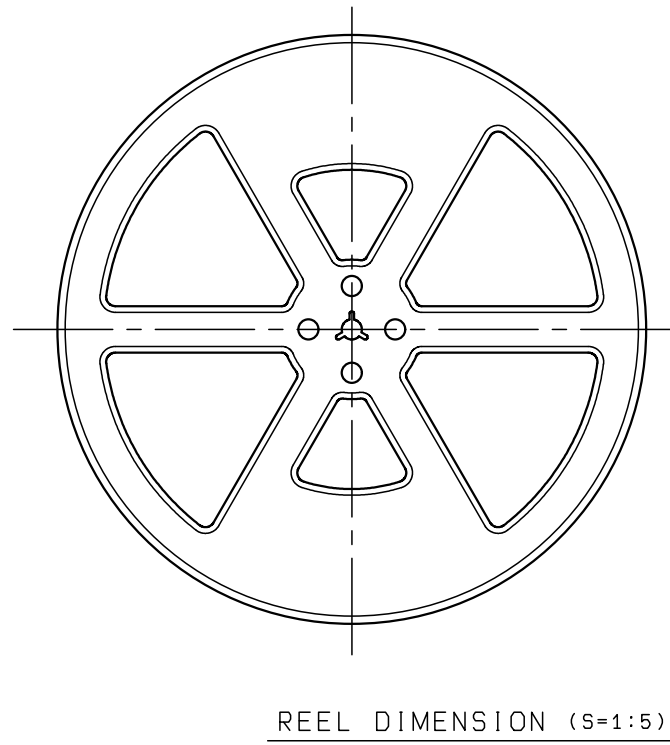
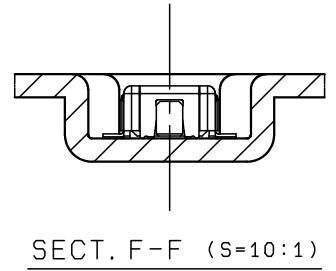

ROHS規制対応
 COMPLIANT WITH
 ROHS REGULATIONS

TOLERANCE / 一般公差(S)		PRODUCT SPEC / 製品規格		REFER TO SHEET 1/2		
X < 10	±0.2	UNIT	ANGLE	NO.	EDN/DCN	DATE
10 ≤ X < 30	±0.25	mm	3RD	ISSUE	CHECKED	APPROVED
30 ≤ X	±0.3	SCALE	DATE	PART NAME / 品名		
ANGLE / 角度	±3°	3:1	2015/05/10	SERIES 5863 PLUG EMBOSS ASSY BOARD TO BOARD H=0.8		
DRAWN	DESIGNED	CHECKED	APPROVED	PART NO. / 型番		
G. IKEDA	G. IKEDA	K. HIRATA	K. YAMANE	14 5863 XXX 024 829 +		
DWG NO. / 図番				SHEET/REV		
BJS 5863007				12/2 H		