

NO.	DESCRIPTION	PART NO.	QTY	MATERIAL	DRW NO.	REMARKS
1	INSULATOR		1	HEAT RESISTING PLASTIC		COLOR: BLACK UL94V-0
2	CONTACT		N	COPPER-ALLOY		Au, Be-Free
3	ANCHOR PLATE		2	COPPER-ALLOY		Au, Be-Free

極数 NO. OF POS.	A	B	C	D	E	F
6	0.70	2.42	3.40	2.10		3.32
10	1.40	3.12	4.10	2.80		4.02
12	1.75	3.47	4.45	3.15		4.37
16	2.45	4.17	5.15	3.85		5.07
18	2.80	4.52	5.50	4.20		5.42
20	3.15	4.87	5.85	4.55		5.77
24	3.85	5.57	6.55	5.25		6.47
30	4.90	6.62	7.60	6.30		7.52
34	5.60	7.32	8.30	7.00		8.22
40	6.65	8.37	9.35	8.05		9.27
42	7.00	8.72	9.70	8.40		9.62
44	7.35	9.07	10.05	8.75		9.97
46	7.70	9.42	10.40	9.10		10.32
48	8.05	9.77	10.75	9.45		10.67
50	8.40	10.12	11.10	9.80		11.02
54	9.10	10.82	11.80	10.50		11.72
60	10.15	11.87	12.85	11.55		12.77

※この表は1ページ目のみ適用
 ※THIS CHART IS APPLICABLE TO SHEET-1 ONLY.

注記
 NOTE

① テール及び金具底面の相互の輪郭度は、0.08MAX.
 COPLANARITY OF CONTACT TAIL
 AND ANCHOR PLATE IS 0.08MAX.

② 図示の位置にLOT NO. を刻印する。(レーザー)
 LOT NO. SHALL BE MARKED
 AT THE SPECIFIED POSITION. (LASER)

n S (6P) K n S (10P~18P)
 工場コード 工場コード
 製造週 製造週
 「K」表示(固定)

K 3 01 S (24P~)
 工場コード
 製造日 1, 2, ~29, 30, 31.
 製造月 1, 2, ~9, X, Y, Z.
 「K」表示(固定)

※この注記は1ページ目のみ適用
 ※THIS NOTES IS APPLICABLE TO SHEET-1 ONLY.

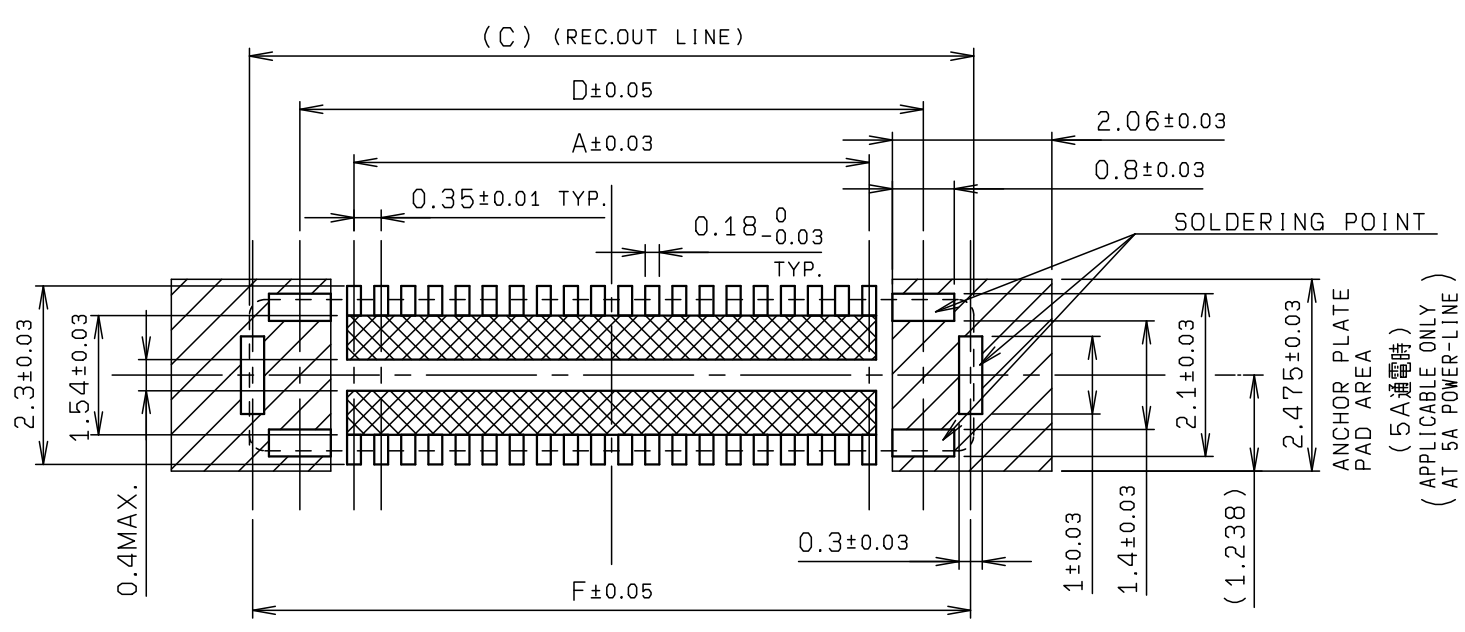
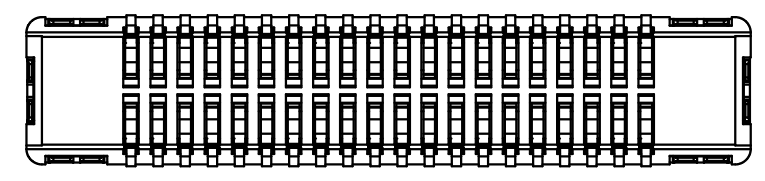
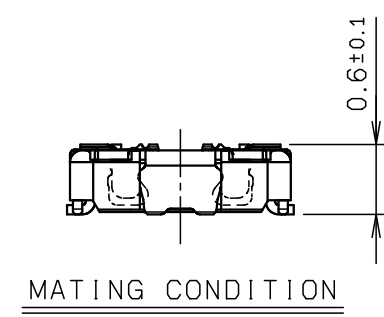
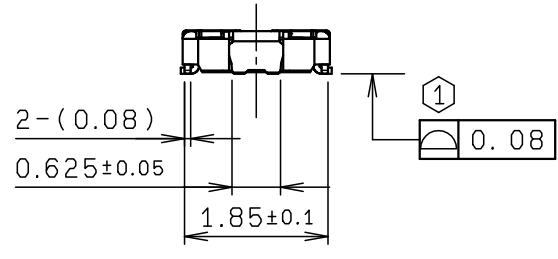
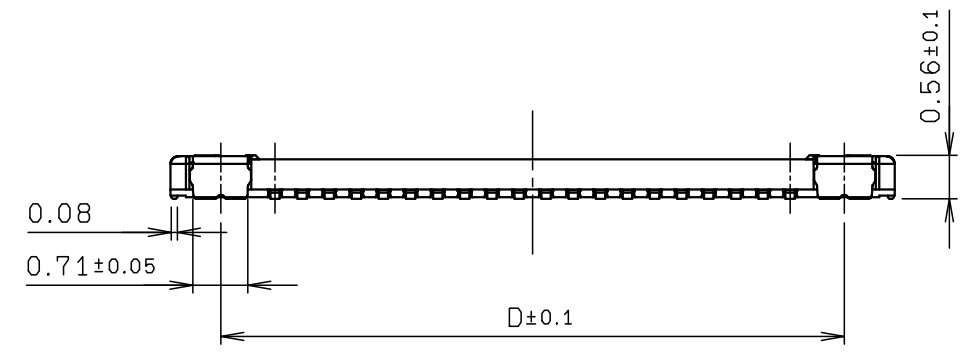
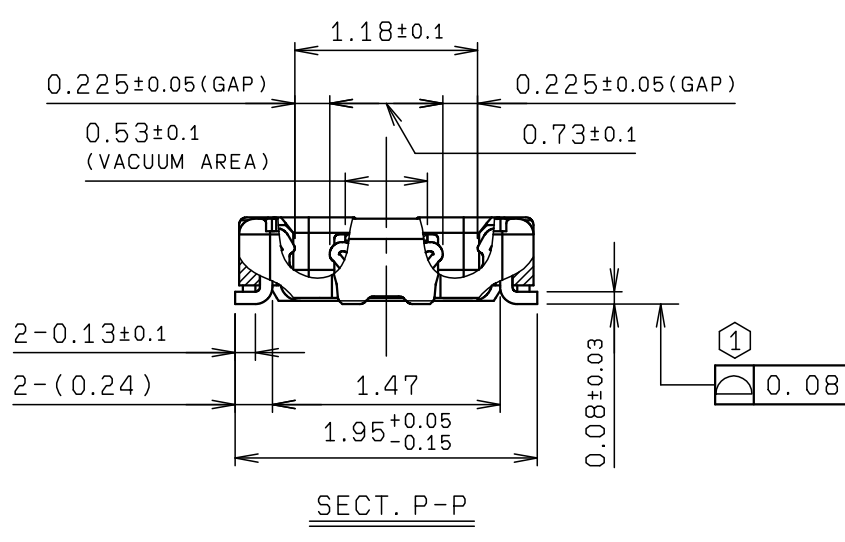
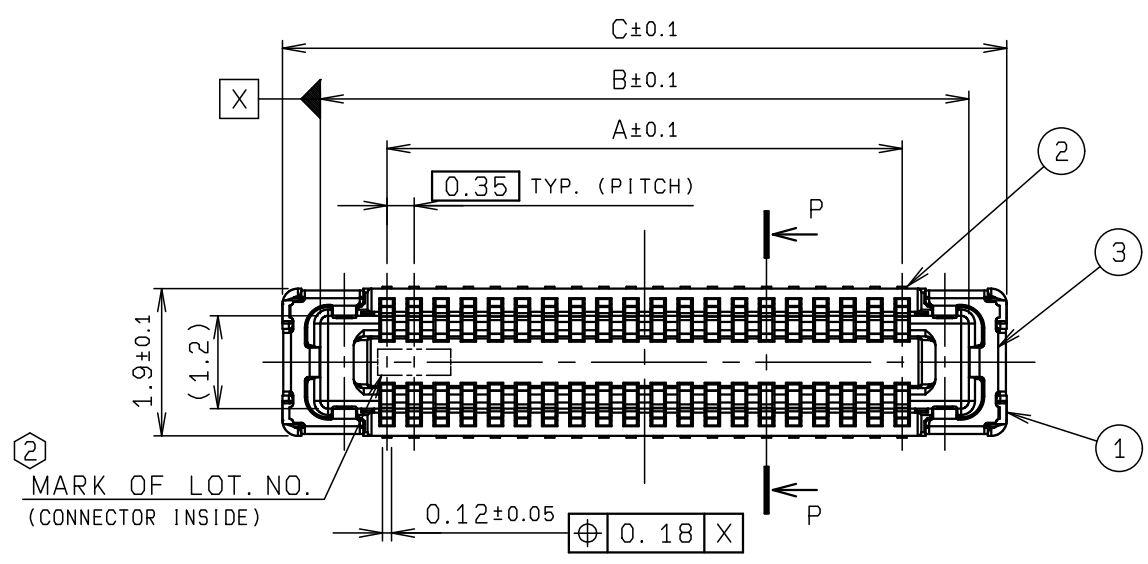

☒ : 絶縁エリア
 INSULATION AREA

ROHS規制対応
 COMPLIANT WITH
 ROHS REGULATIONS

TOLERANCE / 一般公差(S)		PRODUCT SPEC / 製品規格		N	DCN21556	2021/07/13	K. AZUMA	H. WATANABE	S. HORINO
X < 10	±0.2	UNIT		M	DCN19D12	2019/12/02	K. AZUMA	H. WATANABE	A. TSUNEMURA
10 ≤ X < 30	±0.25	mm	ANGLE	O	EDN-459	2015/09/15	K. HIRATA	K. YAMANE	T. SASAKI
30 ≤ X	±0.3		3RD	NO.	EDN/DCN	DATE	ISSUE	CHECKED	APPROVED
ANGLE / 角度	±3°	SCALE	DATE	PART NAME / 品名					
		NTS	2015/09/15	SERIES 5861 REC ASSY 0.35mm PITCH BOARD TO BOARD H=0.6					
DRAWN	DESIGNED	CHECKED	APPROVED	PART NO. / 型番					
K. HIRATA	K. HIRATA	K. YAMANE	T. SASAKI	24 5861 XXX 004 829 +					
DWG NO. / 図番				SHEET		REV			
BJS 5861006				11/2		N			

NO.	DESCRIPTION	PART NO.	QTY	MATERIAL	DRW NO.	REMARKS
1	CONNECTOR	24 5861 XXX 004 829 +	15000			20 5861 XXX 004 829 +
2	EMBOSSSED TAPE		1	POLYSTYRENE		
3	TOP COVER TAPE		1	PET		
4	REEL		1	POLYSTYRENE		

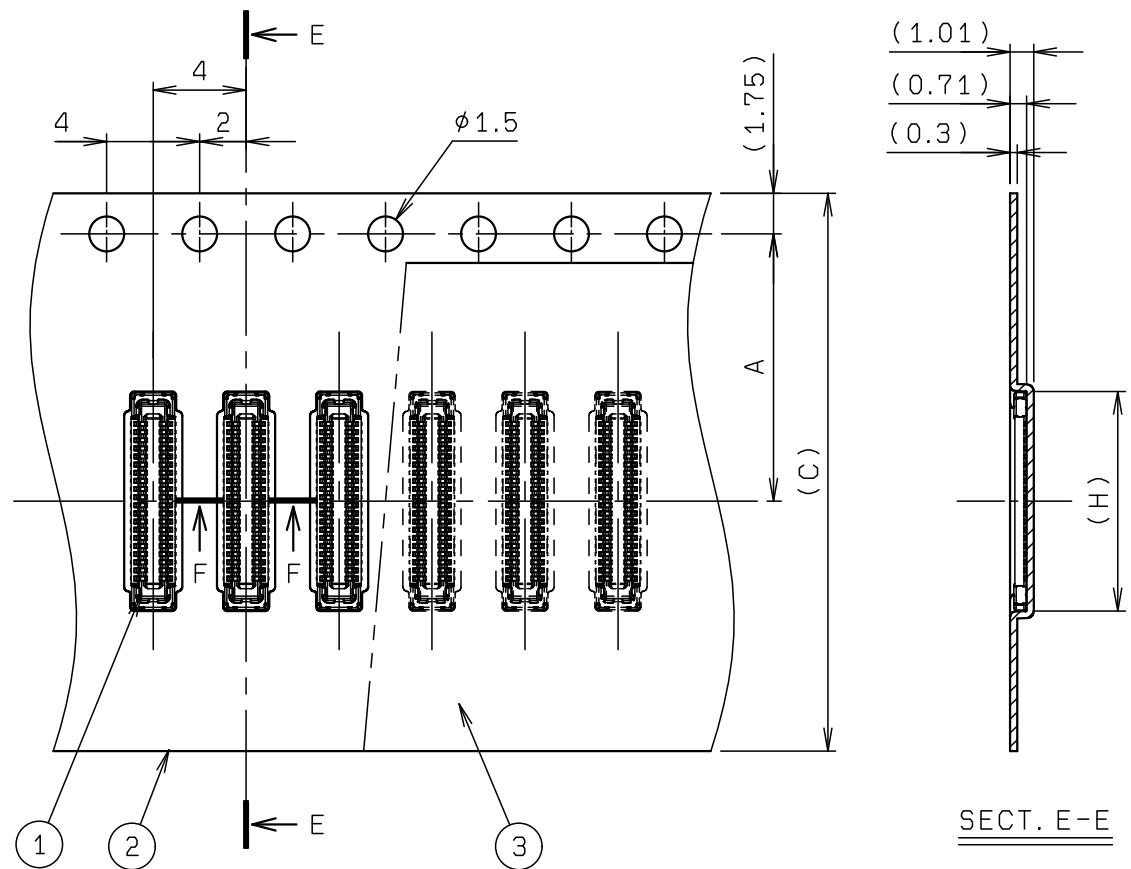

極数 NO. OF POS.	A	B	C	D	H
6	5.5	-	12.0	18.4	3.50
10	5.5	-	12.0	18.4	4.20
12	5.5	-	12.0	18.4	4.55
16	7.5	-	16.0	22.4	5.25
18	7.5	-	16.0	22.4	5.60
20	7.5	-	16.0	22.4	5.95
24	7.5	-	16.0	22.4	6.65
30	7.5	-	16.0	22.4	7.70
34	7.5	-	16.0	22.4	8.40
40	11.5	-	24.0	30.4	9.45
42	11.5	-	24.0	30.4	9.80
44	11.5	-	24.0	30.4	10.15
46	11.5	-	24.0	30.4	10.50
48	11.5	-	24.0	30.4	10.85
50	11.5	-	24.0	30.4	11.20
54	11.5	-	24.0	30.4	11.90
60	11.5	-	24.0	30.4	12.95

※この表は2ページ目のみ適用
 ※THIS CHART IS APPLICABLE TO SHEET-2 ONLY.

注記
NOTE

1. 梱包数量 : 15000 個/リール
 PACKING QUANTITY : 15000 ea/reel

2. 納入時のリール巻き方向
 REELING DIRECTION
 IN DELIVERY

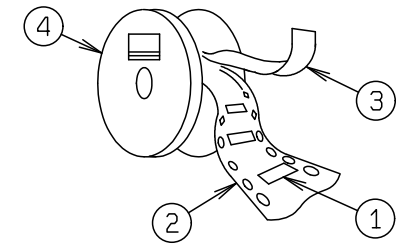

3. 引出し方向
 USER DIRECTION OF FEED

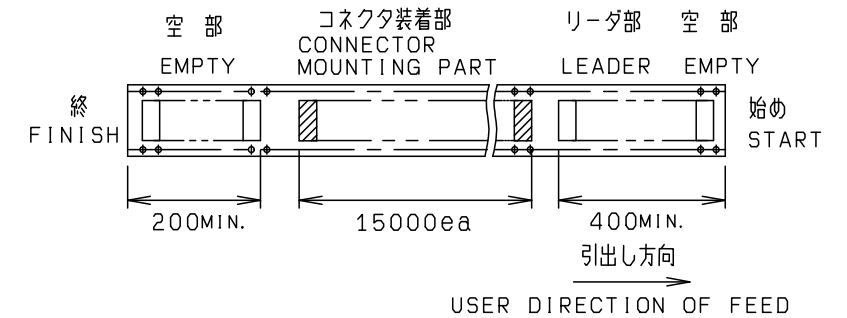

4. 型番 P/N 24 5861 XXX 004 829 +
 極数 NO. OF POS.

※この注記の1~3は2ページ目のみ適用
 ※THIS NOTES 1 TO 3 ARE APPLICABLE TO SHEET-2 ONLY.

ROHS規制対応
 COMPLIANT WITH
 ROHS REGULATIONS

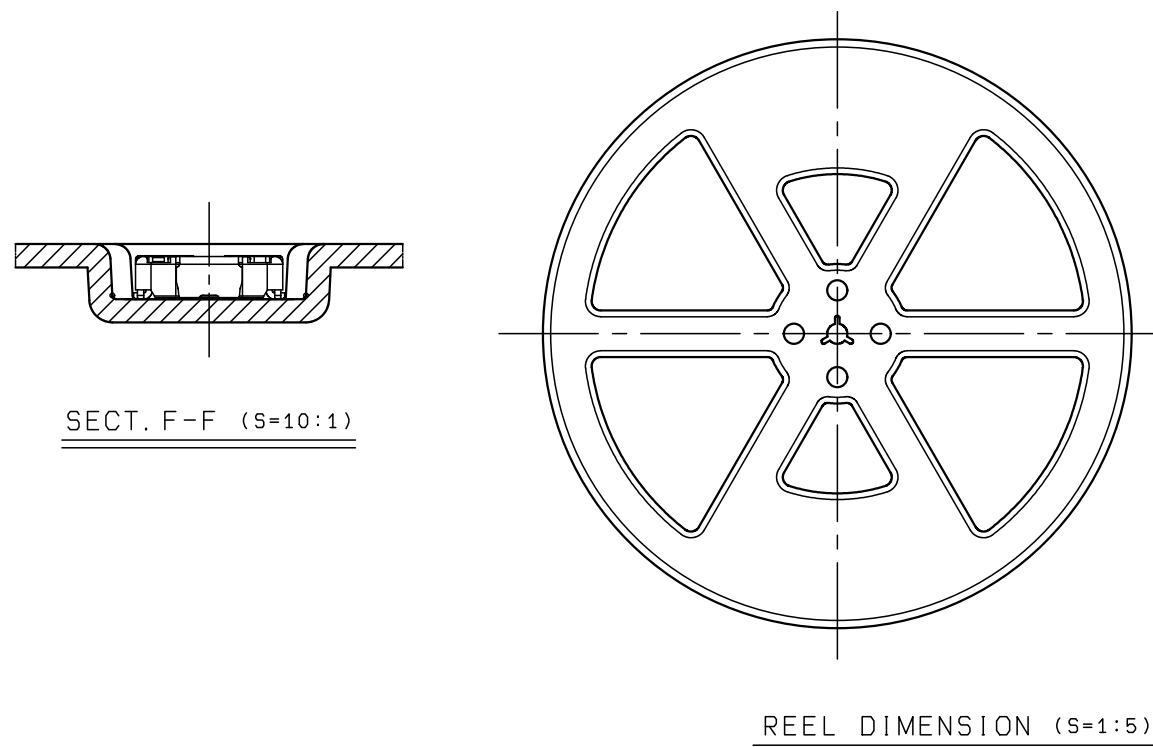

TOLERANCE / 一般公差(S)		PRODUCT SPEC / 製品規格		REFER TO SHEET 1/2		
X < 10	±0.2	UNIT	ANGLE	NO.	EDN/DCN	
10 ≤ X < 30	±0.25	mm	3RD	DATE	ISSUE	
30 ≤ X	±0.3	SCALE	DATE	CHECKED	APPROVED	
ANGLE / 角度	±3°	3 : 1	2015/09/15	PART NAME / 品名		
DRAWN M. TAKAHASHI		DESIGNED K. HIRATA	CHECKED K. YAMANE	APPROVED T. SASAKI	SERIES 5861 REC EMBOSS TAPE ASSY SMT	
DWG NO. / 図番		PART NO. / 型番		0.35mm PITCH BOARD TO BOARD H=0.6 W=1.95		
BJS 5861006		24 5861 XXX 004 829 +				
SHEET/REV		12/2		N		