

RoHS規制対応
COMPLIANT WITH
RoHS REGULATIONS

NO.	DESCRIPTION	PART NO.	QTY	MATERIAL	DRW NO.	REMARKS
1	INSULATOR		1	Heat Resist Resin		COLOR:BLACK
2	CONTACT		XXX	Copper Alloy		t0.15 Au:CONTACT AREA, TAIL AREA
3	ANCHOR PLATE		2	Copper Alloy		t0.2 Sn-Cu
4	VACUUM TAPE		1	HEAT RESIST		

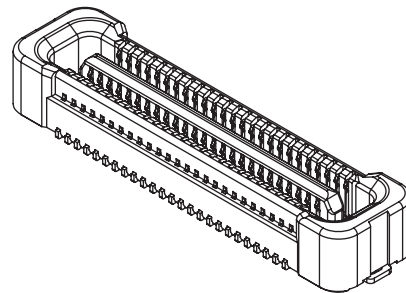

Pin Num.	A	B	C	D	E	F
10	8	2	5.6	11.8	5.4	4.7
12	8.5	2.5	6.1	12.3	5.9	5.2
20	10.5	4.5	8.1	14.3	7.9	7.2
30	13	7	10.6	16.8	10.4	9.7
40	15.5	9.5	13.1	19.3	12.9	12.2
50	18	12	15.6	21.8	15.4	14.7
60	20.5	14.5	18.1	24.3	17.9	17.2
70	23	17	20.6	26.8	20.4	19.7
80	25.5	19.5	23.1	29.3	22.9	22.2

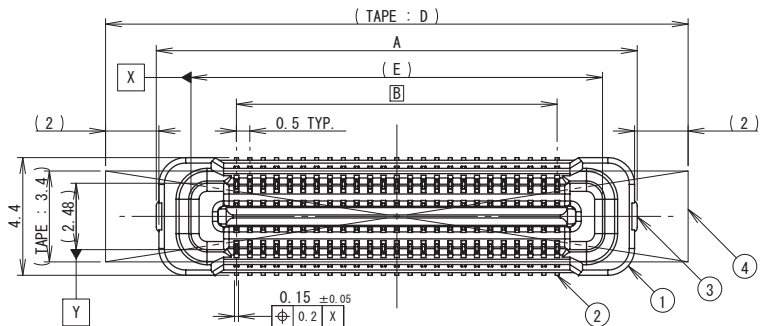
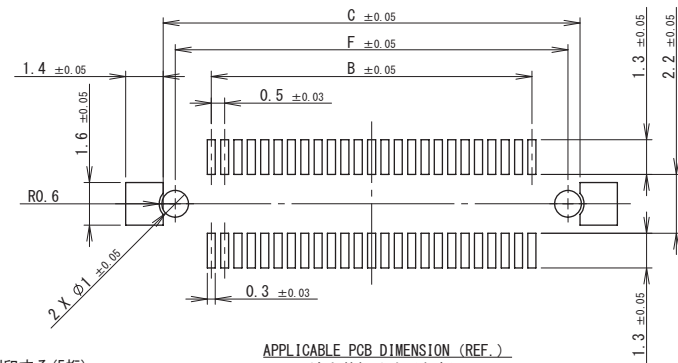
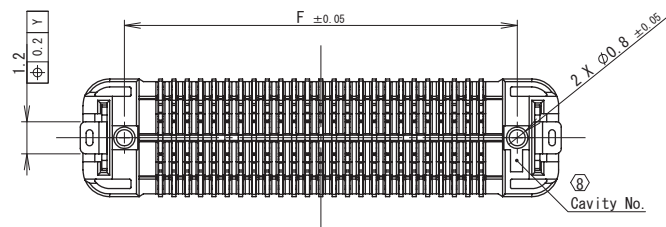
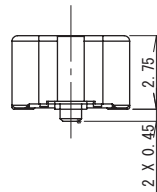
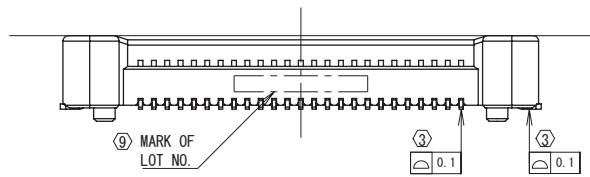

注記 NOTE

1. フローティング可動量 (可動側: PLUG)
FLOATING RANGE (MOVABLE SIDE: PLUG)
ピッチ方向: ±0.5mm / PITCH DIRECTION
スパン方向: ±0.5mm / SPAN DIRECTION
対角方向: ±0.5mm / DIAGONAL

2. 高さ許容量: ±0.5mm / HEIGHT RANGE

③. コンタクトテール、金具輪郭度0.1mm MAX.
CONTACT TAIL, ANCHOR PLATE COPLANARITY 0.1mm MAX.

4. 使用時は、コネクタのみで基板を保持せずスペーサなど設置下さい。
IN ADDITION TO THE CONNECTOR, INSERT A SPACER OR SUCH BETWEEN THE MATED BOARD.

5. フローティングを最大ストロークさせた後に再利用する場合は、事前に確認の上ご使用ください。
USE THE PLUG CONNECTOR ON THE CONFIRMATION WHEN REUSING AFTER HAVING LET IT STROKE FLOATING TO THE MAXIMUM.

6. 片側だけで抜去 (嵌合) しないで下さい。可能な限り両サイド均等に抜去して下さい。

PLEASE DO NOT UNMATE (MATE) ONLY ONE SIDE. BE SURE TO UNMATE EQUALLY BOTH SIDES AS MUCH AS POSSIBLE.

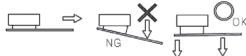

7. TAPEは嵌合面の凹凸により、隙間が生じる場合があります。
A CLEARANCE WILL BE MADE BETWEEN VACUUM TAPE AND THE CONNECTOR BY THE LACK OF FLATNESS ON THE CONNECTOR TOP.

⑧. 図示の位置にCAVITY NO. を刻印する (数字の1~4)。
CAVITY NO. SHALL BE MARKED AT THE SPECIFIED POSITION. (Numbers 1 to 4)

⑨. 図示の位置にLOT NO. を刻印する (5桁)。
LOT NO. SHALL BE MARKED AT THE SPECIFIED POSITION. (5 DIGIT)

7 2 18 X (2017/02/18)
工場コード (Factory Code)
製造日 (Day) 1, 2, ~29, 30, 31.
製造月 (Month) 1, 2, ~9, X, Y, Z.
製造年 (Year) 2000~2009: A, B, ~K (NOT USE "1")
2010~2019: 0, 1, ~9
(20 YEAR CYCLE)

※この注記は1ページ目へのみ適用
※THIS NOTE IS APPLICABLE TO SHEET-1 ONLY.

TOLERANCE / 一般公差 (S)		MATERIAL / 材質		E	DCN24714	2024/12/26	Y. OKABE	M. YOSHIDA
X < 10	±0.2			D	DCN24331	2024/05/15	S. HIBINO	M. YOSHIDA
10 ≤ X < 30	±0.25	UNIT	ANGLE	0	EDN18198	2018/07/09	S. MORITA	F. IKEGAMI
30 ≤ X	±0.3	mm	3RD	NO. / EDN/DCN DATE ISSUE CHECKED APPROVED				
ANGLE / 角度	±3°	SCALE	DATE	PART NAME / 品名				
		5 : 1	2018/07/09	SERIES 5655 REC ASSY ST SMT H=4				
DRAWN	DESIGNED	CHECKED	APPROVED	0.5mm PITCH FLOATING BOARD TO BOARD				
S. MORITA	S. MORITA	F. IKEGAMI	M. YOSHIDA	PART NO. / 型番				
				24 5655 XXX 40X 829 + T				
				DWG. NO. / 図番				
				BJS 5655002				
				SHEET		REV		
				1/2		E		



RoHS規制対応
COMPLIANT WITH
RoHS REGULATIONS

NO.	DESCRIPTION	PART NO.	QTY	MATERIAL	DRW NO.	REMARKS
1	CONNECTOR	24 5655 XXX 40X 829+ T	1000			20 5655 XXX 40X 829+ T
2	EMBOSS TAPE		1	POLYSTYRENE		
3	TOP COVER TAPE		1	PET		
4	REEL		1	POLYSTYRENE		

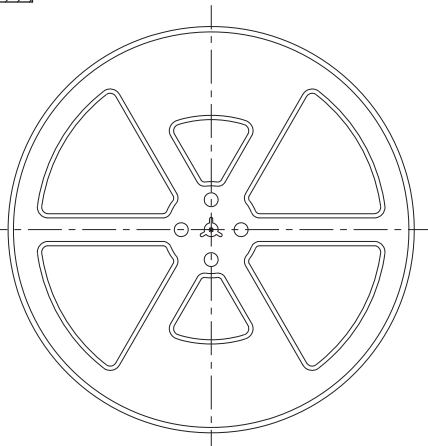
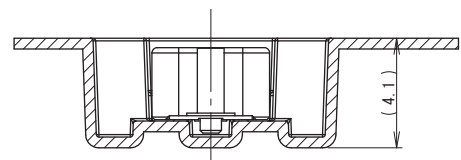
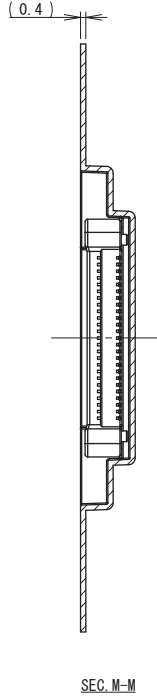
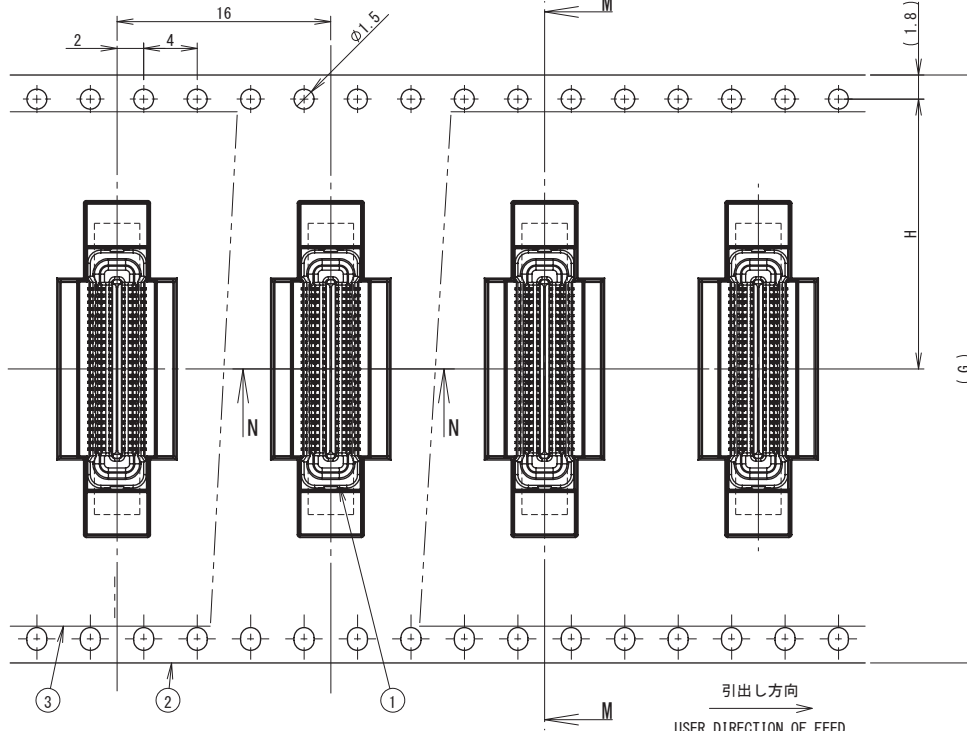

注記
NOTE
1. 梱包数量：1000個/リール
PACKING QUANTITY：1000ea/reel

2. 納入時のリール巻き方向
REELING DIRECTION IN DELIVERY

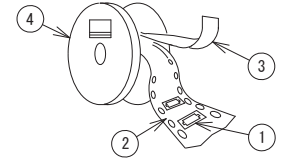

3. 引出し方向
USER DIRECTION OF FEED

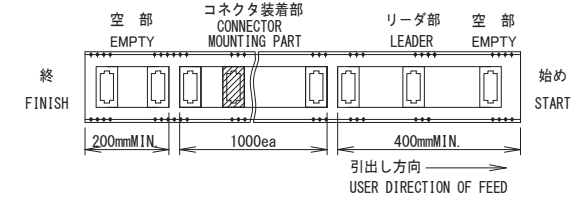

4. 型番
P/N 24 5655 XXX 40X 829 + T

24 : REC EMBOSS ASSY
5655 : Series

極数 NO OF POS. 010~080 : 10~80 PINS

バリエーション VARIATION

高さ HEIGHT 40 : H=4

ボス BOSS
0 : ボス無、吸着テープ有 WITHOUT BOSS, WITH VACUUM TAPE
1 : ボス有、吸着テープ有 WITH BOSS AND VACUUM TAPE

めっきコード PLATING CODE
829+ : Ni UNDER COAT 1.5~5μm
CONTACT AREA : Au 0.1μm MIN.
TAIL AREA : Au 0.03μm MIN.

※この注記の1~3は2ページ目にも適用
※THESE NOTES 1 TO 3 ARE APPLICABLE TO SHEET-2 ONLY.

Pin Num.	G	H	K
10	32	14.2	38.4
12	32	14.2	38.4
20	32	14.2	38.4
30	44	20.2	50.4
40	44	20.2	50.4
50	44	20.2	50.4
60	44	20.2	50.4
70	56	26.2	62.4
80	56	26.2	62.4

TOLERANCE / 一般公差(S)		MATERIAL / 材質		REFER TO SHEET 1/2					
$X < 10$	±0.2	UNIT	ANGLE	NO.	EDN/DCN	DATE	ISSUE	CHECKED	APPROVED
$10 \leq X < 30$	±0.25	mm	3RD	PART NAME / 品名					
$30 \leq X$	±0.3	SCALE	DATE	SERIES 5655 REC ST SMT H=4 / EMBOSS ASSY					
ANGLE / 角度	±3°	NTS	2018/07/09	0.5mm PITCH FLOATING BOARD TO BOARD					
DRAWN	DESIGNED	CHECKED	APPROVED	PART NO. / 型番					
S. MORITA	S. MORITA	F. IKEGAMI	M. YOSHIDA	24 5655 XXX 40X 829 + T					
DWG. NO. / 図番				SHEET		REV			
KYOCERA				BJS 5655002		2/2		E	